

Model RM-2 Riser Manifold

General Description

The TYCO Model RM-2 Riser Manifold features the necessary waterflow alarm, pressure gauge, alarm test orifice, drain, sight glass and check valve equipment in a single assembly for use in National Fire Protection Association (NFPA) standard NFPA 13* compliant commercial sprinkler systems.

The riser manifold is available in a 2 in. to 6 in. range of sizes, and provides a cost effective and easy transition arrangement to control valves and system piping. The riser manifold may be installed in either a horizontal or vertical orientation, for both single sprinkler rises and floor control in high-rises.

A TYCO Model TD-2 Test and Drain Valve installed on the riser manifold as shown in Figure 2 provides a simplified means for testing of waterflow alarm devices and draining for feed mains.

The pressure relief valve, integrated in the TYCO Model TD-2 Test and Drain Valve, has an adjustable range of 100 psi (6,9 bar) to 310 psi (21,4 bar). Excess system pressure is exhausted internally through the TD-2 valve's drain outlet. For more information about the Model TD-2 Test and Drain Valve, refer to Technical Data Sheet TFP965.

* Although the Riser Manifold described in this technical data sheet is intended for the NFPA 13 sprinkler systems, it may be used for NFPA 13D or 13R residential sprinkler systems, where a test orifice of 2.8K or 4.2K is acceptable.

NOTICE

The TYCO Model RM-2 Riser Manifold described herein must be installed and maintained in compliance with this document, as well as with the applicable standards of the NATIONAL FIRE PROTECTION ASSOCIATION (NFPA), in addition to the standards of any other authorities having jurisdiction. Failure to do so may impair the performance of these devices.

The owner is responsible for maintaining their fire protection system and devices in proper operating condition. Contact the installing contractor or product manufacturer with any questions.

Technical Data

Approvals

UL and C-UL Listed
FM Approved Components
Listed by California State Fire Marshall

Note: Any alteration to the assembly voids UL approval and the product warranty.

Maximum Working Pressure

300 psi (20,7 bar)

Friction Loss

See Table A

Available Sizes

2 in. (DN50)
2-1/2 in. (DN65)
3 in. (DN80)
4 in. (DN100)
6 in. (DN150)

Test Orifice

2 to 3 in. (DN50 to DN80) Manifolds: 2.8K
4 to 6 in. (DN100 to DN150) Manifolds: 4.2K



IMPORTANT

Refer to Technical Data Sheet TFP2300 for warnings pertaining to regulatory and health information.

No	Qty	Part Description	CH	Part Number or Specification				
				2 (DN50)	2-1/2 (DN65)	3 (DN80)	4 (DN100)	6 (DN150)
1	1	Model BFV-300 Butterfly Valve, G x G		59300G025WS	59300G025WS	59300G030WS	59300G040WS	59300G060WS
2	1	Figure 716 Reducing Grooved Coupling		7162520ES	—	—	—	—
		Figure 577 Rigid Grooved Coupling		—	57725ACP	57730ACP	57740ACP	57760ACP
3	2	Figure 577 Rigid Grooved Coupling		57720ACP	57725ACP	57730ACP	57740ACP	57760ACP
4	1	Groove x Groove Nipple, Flow Switch		5940020	5940025	5940030	5940040	5940060
5	1	Waterflow Alarm Switch, Potter VSR		24110	24111	24112	24114	24116
6	1	Model CV-1FR Riser Check Valve		595901020RM	595901025	595901030	595901040	595901060
7	1	Groove x Groove x Thread Tee, TD-2		5940021	5940026	5940031	5940041	5940061
8	1	Model TD-2 Test 1-1/4" x 2.8K Orifice		598321			—	
		and Drain Valve 2" x 4.2K Orifice		—			598322	
9	1	Model RM-2 Identification Tag		5941020	5941025	5941030	5941040	5941060
10	1	Water Pressure Gauge, 300 psi/2000 kPa		923431005	923431005	923431005	923431005	923431005
11	1	1/4" Gauge Test Valve		460051003	460051003	460051003	460051003	460051003
12	1	Pipe Nipple, Galvanized	✓	1/4" x 3"				1/4" x 3-1/2"
13	2	Pipe Plug, Galvanized	✓	1/4"				
14	1	Pipe Plug, Galvanized	✓	1-1/4"			2"	

NOTES

1. CH = Common Hardware
2. Refer to Technical Data Sheet TFP950 for information on Model CV-1FR Riser Check Valve replacement parts

Nominal Valve Size, in. (DN)	Nominal Dimensions, in. (mm)						
A	B	C	D	E	F	G	H
2 (DN50)	1-1/4 NPT	23.5 (597)	2.6 (66)	9.4 (239)	8.4 (213)	4.7 (119)	5.1 (130)
2-1/2 (DN65)		24.8 (630)	3.5 (89)	10.0 (254)	8.4 (213)		5.7 (145)
3 (DN80)		25.2 (640)	3.7 (94)	10.2 (259)	8.6 (218)		5.9 (150)
4 (DN100)	2 NPT	28.2 (716)	4.6 (117)	11.1 (282)	9.6 (244)	5.0 (127)	6.6 (168)
6 (DN150)		31.3 (795)	5.9 (150)	12.0 (305)	11.4 (290)		7.5 (191)

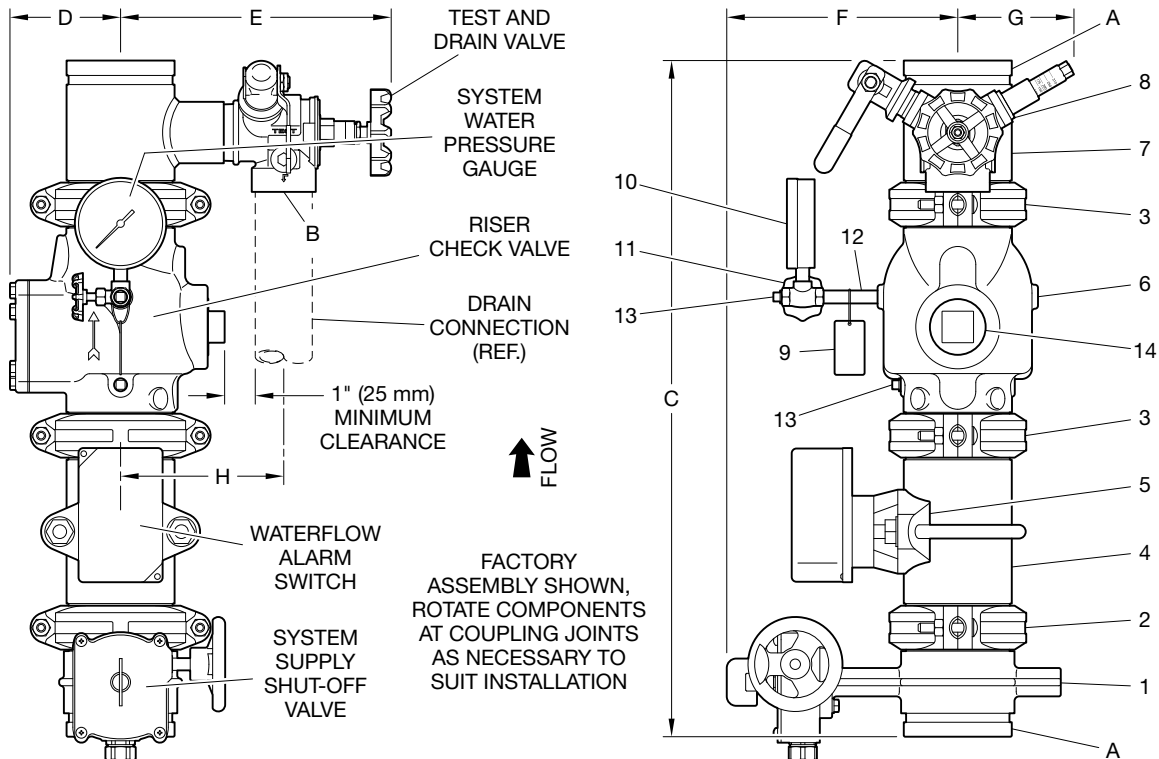

FIGURE 1
MODEL RM-2 RISER MANIFOLD
STANDARD ASSEMBLY AND DIMENSIONS

No	Qty	Part Description	CH	Part Specification				
				2 (DN50)	2-1/2 (DN65)	3 (DN80)	4 (DN100)	6 (DN150)
15	1	Pipe Nipple, Galvanized	✓	1-1/4" x 5"			2" x 3-1/2"	
16	1	Elbow, Galvanized	✓	1-1/4" x 90°			2" x 90°	

NOTES

1. CH = Common Hardware

Dim.	Nominal Dimension in. (mm)				
	2 (DN50)	2-1/2 (DN65)	3 (DN80)	4 (DN100)	6 (DN150)
D	2.6 (66)	3.5 (89)	3.7 (94)	4.6 (117)	5.9 (150)
J	12.2 (310)	12.8 (325)	12.7 (323)	12.0 (305)	13.0 (330)
K	7.8 (198)	8.4 (213)	8.3 (211)	7.2 (183)	8.2 (208)
L	3.9 (99)			5.0 (127)	

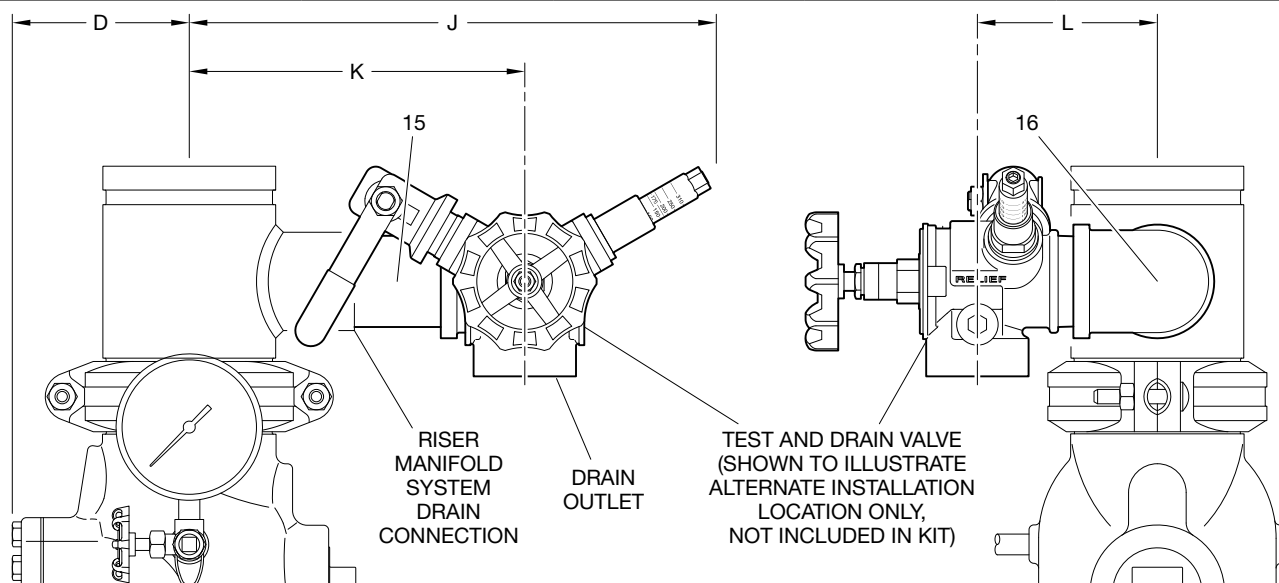

FIGURE 2
MODEL TD-2 TEST AND DRAIN VALVE
ALTERNATE INSTALLATION KIT ARRANGEMENT

Installation

The TYCO Model RM-2 Riser Manifold must be installed in accordance with this section.

The Model RM-2 Riser Manifold may be installed either horizontally or vertically.

Note: Where applicable pipe thread sealant must be applied sparingly. Use of a non-hardening pipe thread sealant is recommended.

Never remove any piping component nor correct or modify any piping deficiencies without first depressurizing and draining the system.

Installing the Riser Manifold

Step 1. Install the manifold assembly with the flow arrow embossed on the riser check valve oriented downstream from the water supply, and secure the end-connections with mechanical grooved couplings listed for fire protection service.

Note: For horizontal installation, ensure the TYCO Model CV-1FR Riser Check Valve is installed with the valve cover up. For more information, refer to Technical Data Sheet TFP950.

Step 2. Connect the drain line and set the Model TD-2 Test and Drain Valve to the CLOSED position.

Step 3. Wire the riser manifold in accordance with the wiring guidance in Figure 3. All wiring must be performed in accordance with the authority having jurisdiction and/or the National Electrical Code.

Step 4. Place the system in service by filling the system with water. When filling the system, partially open the control valve to fill the system slowly. Filling the system slowly helps to avoid damaging the waterflow alarm switch.

After the system is fully pressurized, completely open the control valve.

Step 5. Secure all supply valves open.

Nominal Valve Size ANSI in. (DN)	Equivalent Length of Schedule 40 Pipe ft (m)
2 (DN50)	32 (9,7)
2-1/2 (DN65)	31 (9,4)
3 (DN80)	31 (9,4)
4 (DN100)	36 (10,9)
6 (DN150)	55 (16,7)

TABLE A
FRICTION LOSS
EXPRESSED AS
FLOW THROUGH
EQUIVALENT LENGTH OF
SCHEDULE 40 PIPE

Setting the Pressure Relief Valve

Step 1. Review the pressure relief valve assembly on the test and drain valve as shown in Figure 3.

Step 2. Rotate the pressure relief cap and align the set pressure marks to the the set pressure indicating surface plus (+) or minus (-) a quarter turn.

SWITCH TERMINAL CONNECTIONS

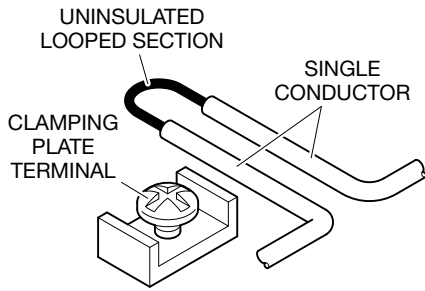

IMPROPER CONNECTION METHOD

CAUTION:
 An uninsulated section of a single conductor is not permitted to be looped around the terminal and serve as two separate connections. The wire must be severed to serve as two separate connections, thereby providing supervision of the connection in the event that the wire becomes dislodged from the terminal.

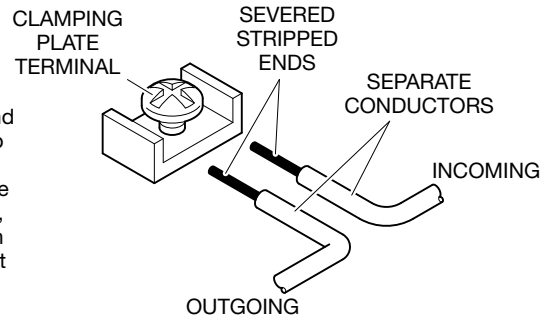

PROPER CONNECTION METHOD

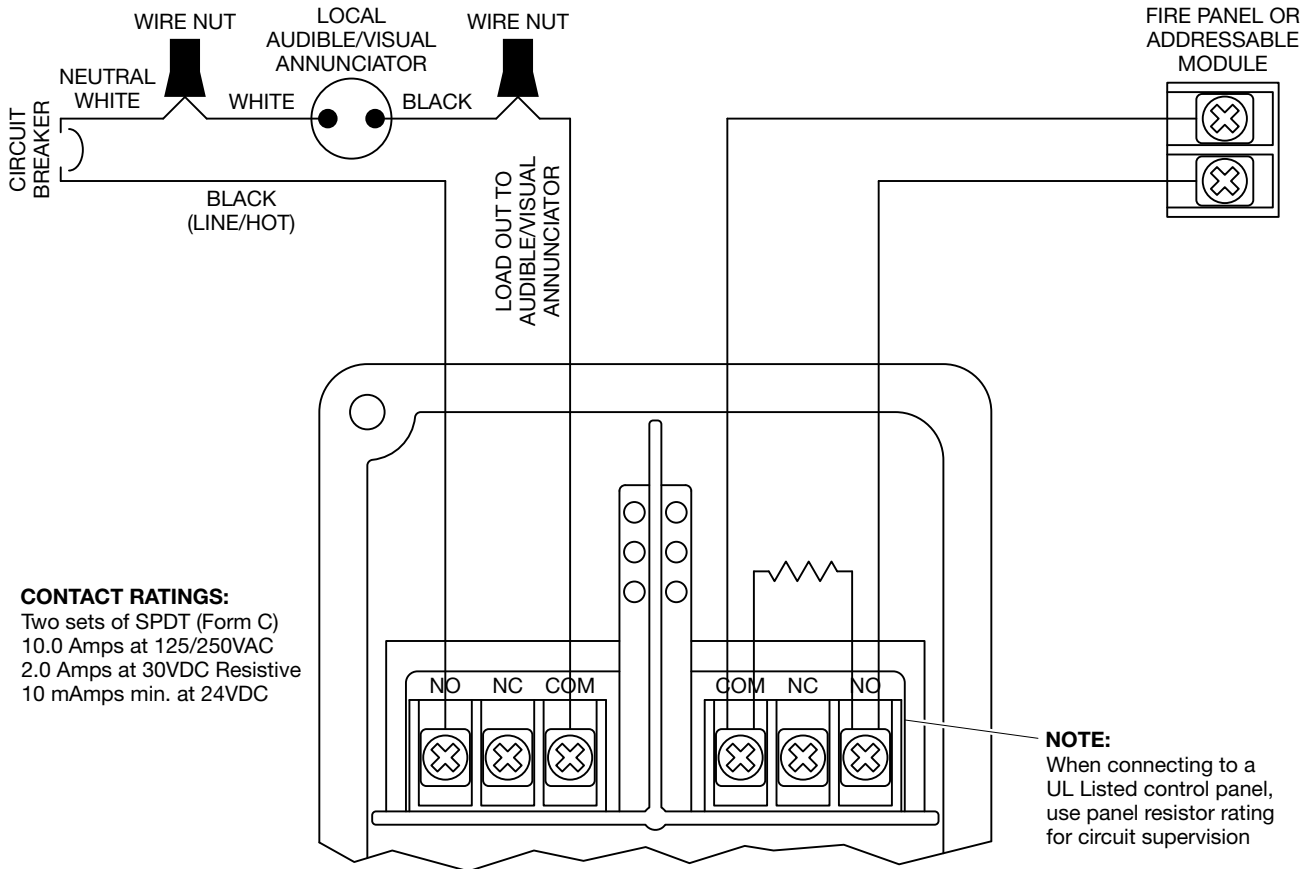

CONTACT RATINGS:
 Two sets of SPDT (Form C)
 10.0 Amps at 125/250VAC
 2.0 Amps at 30VDC Resistive
 10 mAmps min. at 24VDC

NOTE:
 When connecting to a UL Listed control panel, use panel resistor rating for circuit supervision

NOTE:
 For supervised circuits, see "Switch Terminal Connections" above. The Waterflow Alarm Switch has two switches, one can be used to operate a central station, proprietary or remote signaling unit, while the other contact is used to operate a local audible or visual annunciator.

FIGURE 3
MODEL RM-2 RISER MANIFOLD
WIRING GUIDANCE

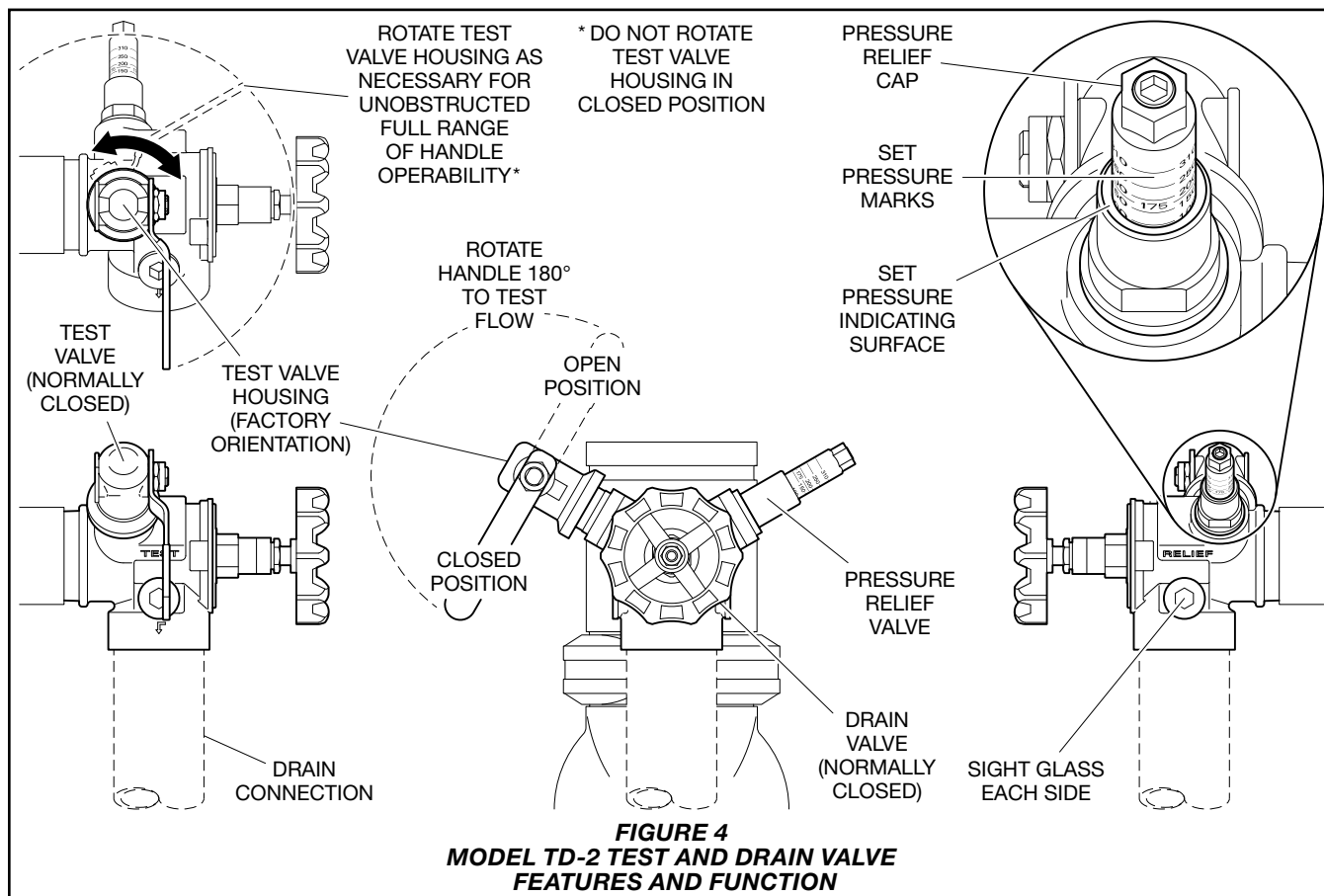

Care and Maintenance

The TYCO Model RM-2 Riser Manifold must be serviced and maintained in accordance with this section.

Before closing a fire protection system control valve for inspection or maintenance work on the fire protection system that it controls, obtain permission to shut down the effected fire protection system from the proper authorities and notify all personnel who may be affected by this action.

After placing a fire protection system in service, notify the proper authorities and advise those responsible for monitoring proprietary and/or central station alarms.

The owner is responsible for the inspection, testing, and maintenance of their fire protection system and devices in compliance with this document, as well as with the applicable standards of the

NATIONAL FIRE PROTECTION ASSOCIATION such as NFPA 25, in addition to the standards of any authority having jurisdiction. Contact the installing contractor or product manufacturer with any questions.

It is recommended that automatic sprinkler systems be inspected, tested, and maintained by a qualified Inspection Service in accordance with local requirements and/or national codes.

Note: With the exception of the Model CV-1FR Riser Check Valve, do not attempt to repair any component of the Model RM-2 Riser Manifold in the field. Refer to Technical Data Sheet TFP950 for CV-1FR repair information. Replace other components as whole assemblies only. See Figure 1 for component descriptions and part numbers.

The alarm/flow test procedure results in operation of the associated alarms. Notify the owner and the fire department, central station, or other signal station to which the alarms are connected, and the building occupants.

The following inspection procedure must be performed as indicated, in addition to any specific requirements of the NFPA, and any impairment must be immediately corrected:

Alarm/Flow Test Procedure

Step 1. Rotate the test valve handle 180 degrees to the OPEN position as shown in Figure 4.

Note: This action permits water to flow through the orifice of the test valve simulating flow from an individual sprinkler located downstream of the waterflow alarm switch as shown in Figure 1.

Note: The test valve housing can be rotated 360 degrees to eliminate equipment interference with the test valve handle as shown in Figure 4.

Do not rotate the test valve housing in the closed position.

Step 2. Confirm water flow through the test port by observing flow at the drain port sight glass.

Step 3. Verify proper operation of the waterflow alarm switch at the fire panel, the addressable module, and the local audible/visual annunciator if installed as shown in Figure 3.

Step 4. Rotate the test valve handle 180 degrees back to the CLOSED position.

Limited Warranty

For warranty terms and conditions, visit www.tyco-fire.com.

Ordering Procedure

Contact your local distributor for availability. When placing an order, indicate the full product name, including description and part number (P/N).

Model RM-2 Riser Manifold

Specify: Model RM-2 Riser Manifold, Size (specify), P/N (specify)

2 in. (DN50)	5940601
2-1/2 in. (DN65)	5940611
3 in. (DN80)	5940621
4 in. (DN100)	5940651
6 in. (DN150)	5940661

Optional Test and Drain Valve Alternate Installation Kit

Specify: Size Range (specify) Model RM-2 Riser Manifold, Test and Drain Valve Alternate Installation Kit, P/N (specify)

2 to 3 in. (DN50 to DN80)	59352691
4 to 6 in. (DN100 to DN150)	59352692

Replacement Parts

See Figure 1 for part descriptions and part numbers.

Specify: Model RM-2 Riser Manifold, replacement (specify part description), P/N (specify)