

Model WMA-1 Water Motor Alarm Hydraulically-Operated Mechanical Sprinkler Alarm European Conformity, 16 bar

General Description

The TYCO Model WMA-1 Water Motor Alarm is a hydraulically-operated outdoor alarm designed for use with fire protection system waterflow detection valves. It is lightweight yet rugged, and can be used in conjunction with alarm check, dry pipe, deluge, and pre-action valves to sound a local alarm.

The Water Motor Alarm is suitable for mounting to any type of rigid wall and can accommodate a wall thickness range of 50 mm to 450 mm. It is provided with a Listed and Approved Model 74A Y-Strainer (P/N 305004) for use in the alarm line.

The WMA-1 utilizes a lightweight, impeller design that can produce a very high sound pressure level. The Gong, Gong Mount, and Water Motor Housing are fabricated from corrosion-resistant aluminum alloys with a brass nozzle insert. The polymer drive bearings do not require lubrication, and the Gong is closely fitted to the Gong Mount to eliminate the need for a separate cover.

NOTICE

The Model WMA-1 Water Motor Alarm described herein must be installed and maintained in compliance with this document, as well as with the applicable standards of the NATIONAL FIRE PROTECTION ASSOCIATION (NFPA), in addition to the standards of any other authorities having jurisdiction. Failure to do so may impair the performance of these devices.

The owner is responsible for maintaining their fire protection system and devices in proper operating condition. Contact the installing contractor or product manufacturer with any questions.

IMPORTANT

Refer to Technical Data Sheet TFP2300 for warnings pertaining to regulatory and health information.

Technical Data

Approvals

FM and VdS Approved
CE Certified

Gong Finish

Red or Aluminum

Working Water Pressure Range

0,5 to 16,0 bar

Nozzle K-factor

10,1 Lpm/bar^{1/2}

Y-Strainer

DN20, bronze, 0,65 mm mesh screen

Trim Components

DN20 galvanized steel nipples and cast iron fittings

Design Criteria

The TYCO Model WMA-1 Water Motor Alarm must be used in accordance with the following design criteria:

Item 1. The Y-strainer is to be located at the inlet to the Water Motor Alarm (Ref. Figure 2).

Item 2. The Water Motor Alarm must only be mounted to a rigid wall surface which will not permit the Striker / Gong Mount to loosen and fall out of alignment.

Item 3. In order to obtain the highest possible sound level, the Water Motor Alarm should be located as close as possible to the waterflow detecting valve.

Item 4. The alarm line piping from the alarm outlet of the waterflow detection valve trim to the Water Motor Alarm must be DN20 in. in size throughout and it must be galvanized steel, brass, or other suitable corrosion-resistant material.

Item 5. The alarm line piping must be positioned such that it can be drained back to the waterflow detection valve trim.



Item 6. The Clean-out Sump Plug is to be located vertically below the Inlet to the Water Motor.

Item 7. Piping from the Water Motor Drain must be a minimum DN25 in. in size throughout and directed to an open drain in order to ensure proper drainage for obtaining the maximum sound pressure level.

Note: *The Water Motor Alarm Drain may be connected to the main drain of a waterflow detection valve if a non-spring loaded swing-type check valve is installed in a horizontal portion of the water motor alarm drain piping (before its connection to the main drain).*

Item 8. In order to minimize any wall staining that can be created by drain water, it is recommended that the drain piping from the Water Motor be galvanized steel, brass, or other suitable corrosion-resistant material.

Item 9. Drain water must be directed to prevent accidental damage to property or danger to persons when the alarm is operating or thereafter.

Item 10. The alarm line drain at the waterflow detection valve must be maintained at a minimum temperature of 4°C.

NO.	DESCRIPTION	QTY.	REF.
1	Water Motor	1	92-630-1-021
2	Support Washer	1	NR
3	Drive Shaft Sleeve	1	NR
4	Drive Shaft	1	NR
5	Gong Mount	1	NR
6	Striker	1	See (a)
7	Gong	1	See (a)
8	Cap Nut	1	See (a)
(a) Red Gong Repair Kit includes items: 6, 7 (red), and 8 1 92-630-1-025			
(a) Aluminum Gong Repair Kit includes items: 6, 7 (alum.), and 8 1 92-630-2-025			

NR: Not Replaceable

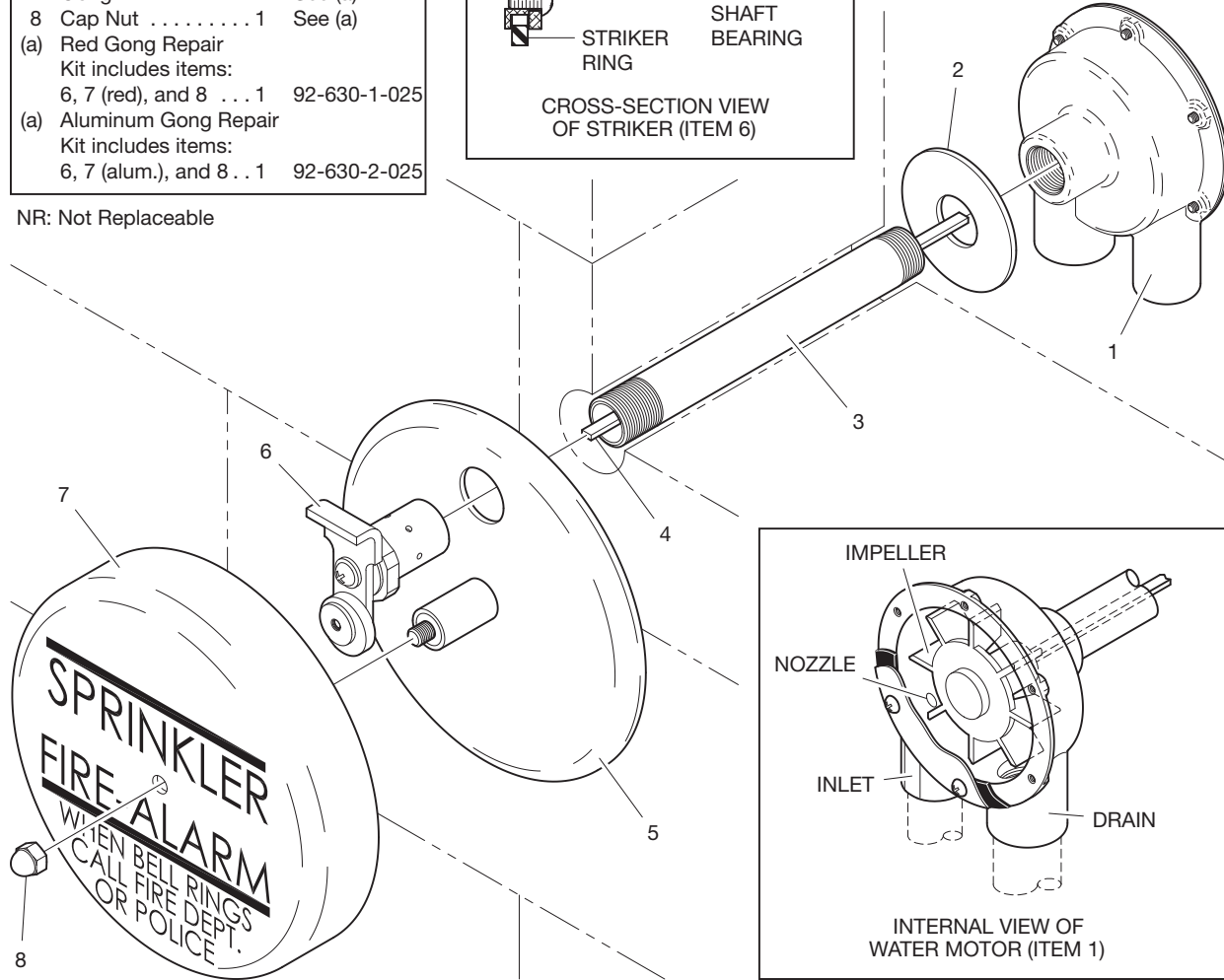
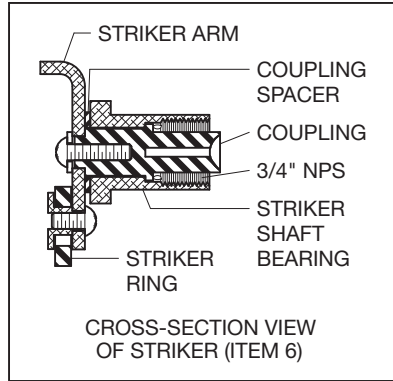

FIGURE 1
MODEL WMA-1 WATER ALARM ASSEMBLY

Operation

Upon operation of the alarm check, dry pipe, deluge, or preaction valve to which the Model WMA-1 Water Motor Alarm is connected, water will flow to the Water Motor and through the Inlet Nozzle. As water flows through the Inlet Nozzle, a high velocity jet is formed which impinges on the Impeller, causing the Impeller and the Striker to rotate. With each rotation, the free swinging Striker Ring hits the Gong and sounds the alarm. The spent water is then drained through the 1 inch outlet.

The alarm will sound as long as water is flowing into the system and flowing to the Water Motor Alarm. Water in the alarm line will automatically drain back through the orifice which is also provided in the trim of the waterflow detection valve.

The Water Motor Alarm does not have to be reset after an operation. However, if the alarm was silenced during operation by closing an alarm control valve, the alarm control valve must be reopened after the fire protection system is restored to service.

Installation

The TYCO Model WMA-1 Water Motor Alarm must be installed in accordance with this section:

Step 1. Mark the through-wall locations for the centerlines of the Sleeve and Drain Outlet. The Drain Outlet must be located at least 250 mm below the Sleeve per Figure 2.

Step 2. Make 38 mm diameter holes straight through the wall at both locations.

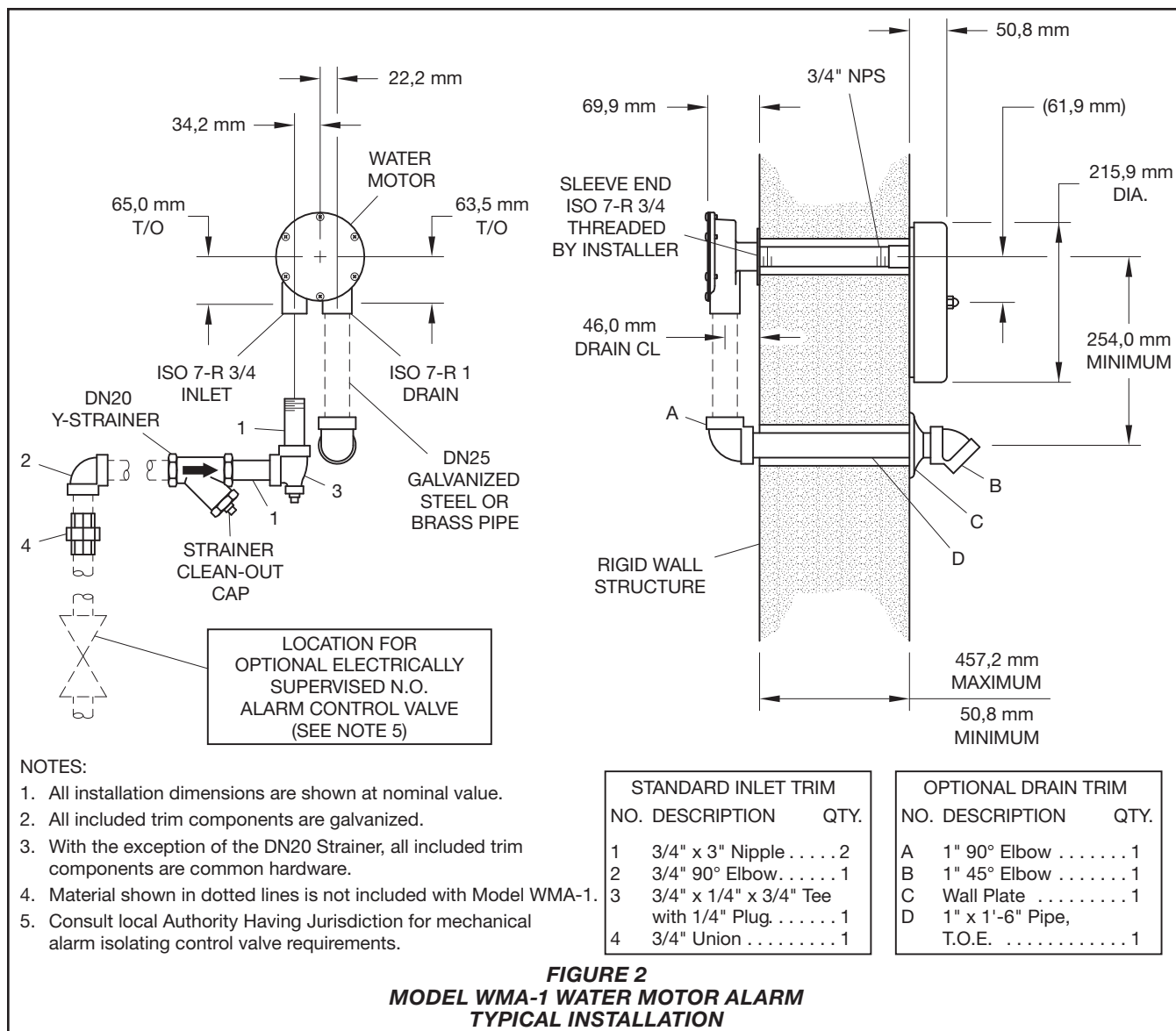

Step 3. Cut the non-threaded end of the Sleeve to a length equal to that of the wall thickness plus 0 to 3 mm. Thread the cut end to ISO 7-R 3/4 per ISO 7-1.

Step 4. Install the alarm line piping up to and including the union half per Item 4, Figure 2.

Note: Use thread sealant sparingly and on male threads only.

Step 5. Prior to initiating installation of the Water Motor Alarm, mount the Drain Trim (less the Wall Plate and 45° Elbow), as well as the balance of alarm line piping including the other union half to the Water Motor.

Step 6. Tighten the ISO-threaded end of the Sleeve into the Body, hand-tight plus 1/8 turn.

Step 7. Slip the Support Washer over the Sleeve and place the assembly in position against the wall.

Step 8. Tighten the DN20 in. Union. Install the Wall Plate and tighten the 45° Elbow.

Note: Apply pressure against the outside edge of the Water Motor body and verify that the body and Support Washer sit square against the wall. If not, adjust the alarm line and/or drain piping to suit.

Step 9. From the outside wall, insert the Drive Shaft through the Sleeve and fully insert it into the Impeller.

Note: When fully inserted, the Shaft should protrude beyond the face of the wall by approximately 500 mm minus 50 mm minus wall thickness.

Mark the Drive Shaft at a point of approximately 3 to 6 mm inside the face of the wall. Remove the Shaft and cut it where previously marked. File off the burrs from the cut end of the Drive Shaft. Re-insert the Drive Shaft through the Sleeve and fully insert it into the Impeller.

Step 10. Hold the Gong Mount in position against the wall, engage the Coupling with the Drive Shaft and then carefully thread the Striker Shaft Bearing onto the Sleeve. Securely tighten the Striker Shaft Bearing using a pair of channel locks on the 38 mm hex end.

Step 11. Spin the Striker by hand and verify that it spins freely, without any sign of binding. If it does not, make the necessary adjustments.

Step 12. Install the Gong and securely tighten the Cap Nut. The identification sign lettering must be orientated horizontally.

Step 13. Test the Water Motor Alarm by opening the alarm test valve in the trim of the waterflow detection valve. The alarm must be clear and steady. If not, make the necessary adjustments.

NOTICE

Testing of the Water Motor Alarm may result in operation of other associated alarms. Consequently, notification must be given to the owner and the fire department, central control station, or other signal station to which the alarms are connected.

Care and Maintenance

The TYCO Model WMA-1 Water Motor Alarm must be serviced and maintained in accordance with this section.

Before closing a fire protection system main control valve for maintenance work on the fire protection system that it controls, permission to shut down the affected fire protection systems must first be obtained from the proper authorities and all personnel who may be affected by this decision must be notified.

The following procedures and inspections should be performed as indicated, in addition to any specific requirements of the authority having jurisdiction, and any impairment must be immediately corrected.

The owner is responsible for the inspection, testing, and maintenance of their fire protection system and devices in compliance with this document, as well as in addition to the standards of any authority having jurisdiction. Contact the installing contractor or product manufacturer with any questions.

It is recommended that automatic sprinkler systems be inspected, tested, and maintained by a qualified Inspection Service in accordance with local requirements and/or national codes.

Testing of the Water Motor Alarm may result in operation of other associated alarms. Consequently, notification must be given to the owner and the fire department.

If the alarm was silenced during operation, the alarm control valve must be reopened immediately after the fire protection system is restored to service.

The Model WMA-1 Water Motor Alarm must be maintained and serviced in accordance with the following instructions:

Step 1. The Model WMA-1 Water Motor Alarm does not require any regularly scheduled maintenance. Rotating parts do not require lubrication. It is recommended, however, that fire alarms be periodically operated, i.e., inspected, to verify that they generate a clear and steady sound. Any impairment must be immediately corrected.

Step 2. The inspection should be made periodically in accordance with the requirements of the authority having jurisdiction, or more frequently as may be necessary in the case of locations subject to vandalism. The Y-Strainer and the Reducing Tee at the WMA-1 inlet are to be cleaned out after each operation of the Water Motor Alarm and after the alarm line piping has been drained.

NOTICE

With reference to Figure 2, in the event of a WMA-1 malfunction, inspect and clean the Y-strainer of obstruction prior to removing the Water Motor.

Make no attempt to disassemble, repair, or internally clean the Water Motor. The Water Motor is not a field serviceable part and must be replaced if malfunction is determined.

Limited Warranty

For warranty terms and conditions, visit www.tyco-fire.com.

Ordering Procedure

Contact your local distributor for availability. When placing an order, indicate the full product name, including description and part number (P/N).

The complete Model WMA-1 Alarm Assembly includes the Model WMA-1 Water Motor Alarm, Model 74A Strainer, and Standard Inlet Trim.

WMA-1 Water Motor Alarm Assemblies (select one)

Specify: Model WMA-1 Alarm Assembly with Red Finish Gong, P/N 52-630-1-021R

Specify: Model WMA-1 Alarm Assembly with Aluminum Finish Gong, P/N 52-630-2-021

Optional Drain Trim

Specify: Optional Drain Trim for Model WMA-1 Water Motor Alarm, P/N 52-630-2-002E

Replacement Parts for WMA-1 Water Motor Alarm

Specify: (specify product description from Figure 1) for use with Model WMA-1 Water Motor Alarm, P/N (specify from Figure 1)

Replacement Trim Parts for WMA-1 Water Motor Alarm

Specify: Model 74A Y-Strainer, P/N 305004