

RAPID RESPONSE Series LFII Residential 4.2 K-factor Concealed Horizontal Sidewall Sprinkler Wet Pipe Systems

General Description

The TYCO RAPID RESPONSE Series LFII Residential 4.2 K-factor Concealed Horizontal Sidewall Sprinkler (TY2324) is a decorative, fast response, fusible link sprinkler designed for use in residential occupancies such as homes, apartments, dormitories, and hotels. The Series LFII Concealed Horizontal Sidewall Sprinkler is intended for use in the following scenarios:

- Wet pipe residential sprinkler systems for one- and two- family dwellings and mobile homes per NFPA 13D
- Wet pipe residential sprinkler systems for residential occupancies up to and including four stories in height per NFPA 13R
- Wet pipe sprinkler systems for the residential portions of any occupancy per NFPA 13

The Series LFII Concealed Horizontal Sidewall Sprinkler is intended for use in areas with finished walls, and provides ¼ in. (6,4 mm) of recessed adjustment. The adjustment reduces the accuracy to which the pipe nipples to the sprinklers must be cut.

The Series LFII Concealed Horizontal Sidewall Sprinkler has been designed with heat sensitivity and water distribution characteristics proven to help

in the control of residential fires and to improve the chance for occupants to escape or be evacuated.

NOTICE

The Series LFII Concealed Horizontal Sidewall Sprinkler described herein must be installed and maintained in compliance with this document and the applicable standards of the NATIONAL FIRE PROTECTION ASSOCIATION (NFPA), in addition to the standards of any authorities having jurisdiction. Failure to do so may impair the performance of these devices.

The owner is responsible for maintaining their fire protection system and devices in proper operating condition. Contact the installing contractor or product manufacturer with any questions.

Sprinkler Identification Number (SIN)

TY2324

Technical Data

Approvals

UL and C-UL Listed (for use with wet pipe systems)
Certified to all requirements of NSF/ANSI 61

See the Design Criteria section for details on these approvals.

Maximum Working Pressure

175 psi (12,1 bar)

Discharge Coefficient

K=4.2 gpm/psi^{1/2} (60,5 lpm/bar^{1/2})

Temperature Rating

160°F (71°C) Sprinkler with
139°F (59°C) Cover Plate

Note: The maximum ambient ceiling temperature for the ordinary temperature configuration is 100°F (38°C).



Horizontal Adjustment

¼ in. (6,35 mm)

Finishes

See the Ordering Procedure section

Physical Characteristics

Body	Brass
Bridge	Bronze
Button	Bronze
Sealing Assembly	Beryllium Nickel w/TEFLON
Soldered Link Halves	Nickel
Compression Screw	Stainless Steel
Trepan	Brass
Deflector	Copper
Deflector Guide Pin	Stainless Steel
Plug	Polyethylene
Lever	Bronze
Retainer	Copper Plated Steel
Cover Plate	Copper
Cover Plate Ejection Spring	Stainless Steel

Operation

When exposed to heat from a fire, the Cover Plate, which is soldered to the Retainer Ring at three points, falls away to expose the Sprinkler Assembly. The link's solder melts when exposed to heat. When the rated temperature is reached, the melted solder releases the link, activating the sprinkler and allowing water to flow.

IMPORTANT

Refer to Technical Data Sheet TFP2300 for warnings pertaining to regulatory and health information.

Always refer to Technical Data Sheet TFP700 for the "INSTALLER WARNING" that provides cautions with respect to handling and installation of sprinkler systems and components. Improper handling and installation can permanently damage a sprinkler system or its components and cause the sprinkler to fail to operate in a fire situation or cause it to operate prematurely.

- | | | | |
|------------------------|-------------------------|------------------------|----------------------------------|
| 1 – Body | 6 – Deflector Guide Pin | 11 – Plug | 16 – Retainer |
| 2 – 1/2 in. NPT | 7 – Frame | 12 – Lever | 17 – Retainer Friction Grip |
| 3 – Wrenching Notch | 8 – Button | 13 – Compression Screw | 18 – Cover Plate Solder Tab |
| 4 – Sprinkler Waterway | 9 – Sealing Assembly | 14 – Link | 19 – Cover Plate |
| 5 – Deflector | 10 – Bridge | 15 – Protective Cap | 20 – Cover Plate Ejection Spring |

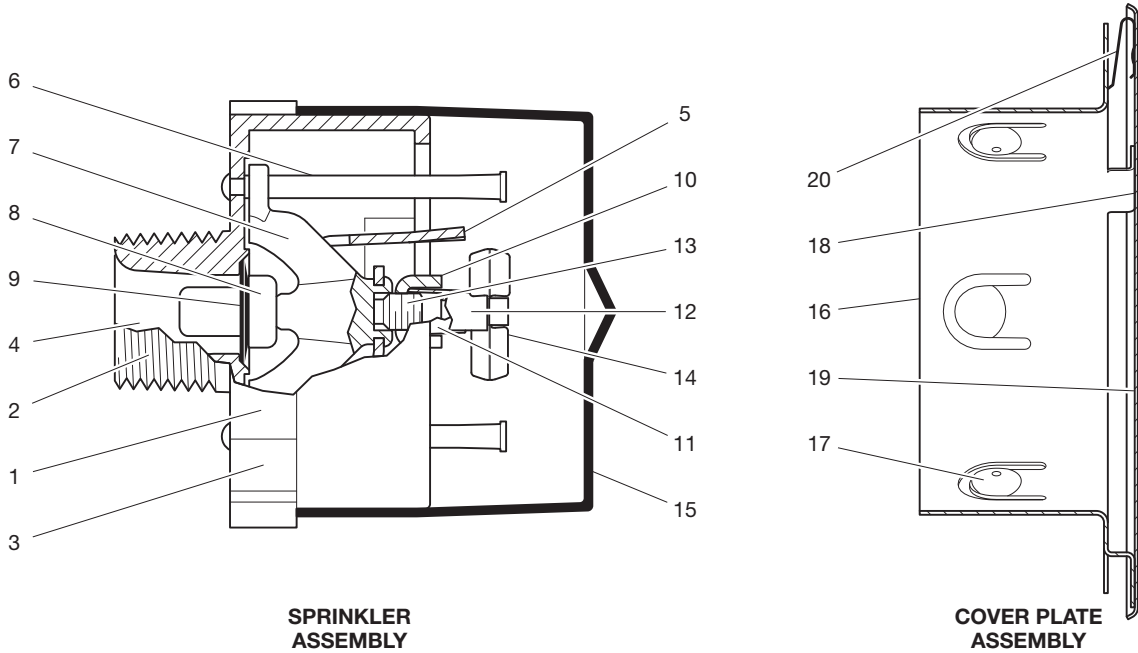

FIGURE 1
SERIES LFII RESIDENTIAL CONCEALED HORIZONTAL SIDEWALL SPRINKLER ASSEMBLY AND FEATURES

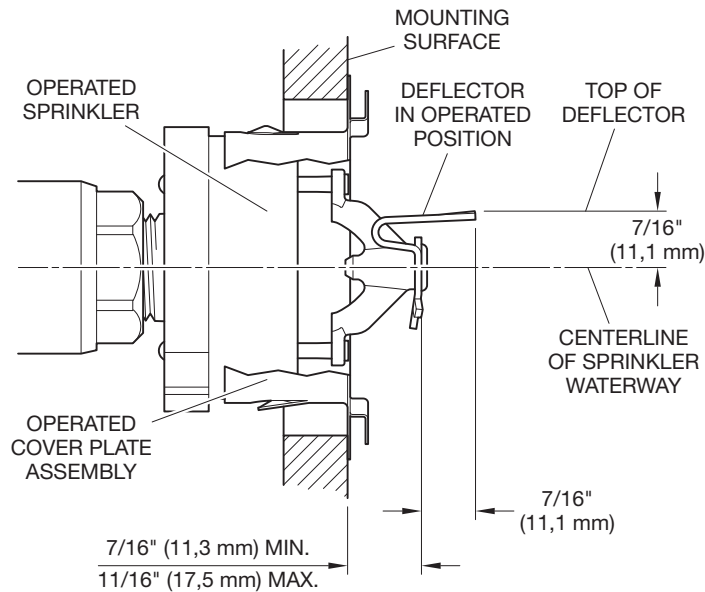

FIGURE 2
SERIES LFII RESIDENTIAL CONCEALED HORIZONTAL SIDEWALL SPRINKLER OPERATED CONDITION

Maximum Coverage Area Width x Length ft x ft (m x m)	Maximum Spacing ft (m)	Wet Pipe System Minimum Flow and Residual Pressure				
		Ordinary Temp. Rating 160°F (71°C)		Top-of-Deflector-to-Ceiling Distance	Center-of-Sprinkler-to-Ceiling Distance	Minimum Spacing ft (m)
		Flow gpm (lpm)	Pressure psi (bar)			
12 x 12 (3,7 x 3,7)	12 (3,7)	12 (45,4)	8.2 (0,57)	4 in. to 6 in.	4-7/16 in. to 6-7/16 in.	8 (2,4)
14 x 14 (4,3 x 4,3)	14 (4,3)	13 (49,2)	9.6 (0,66)			
16 x 16 (4,9 x 4,9)	16 (4,9)	18 (68,1)	18.4 (1,27)			
16 x 18 (4,9 x 5,5)	16 (4,9)	21 (79,5)	25 (1,72)			
12 x 12 (3,7 x 3,7)	12 (3,7)	13 (49,2)	9.6 (0,66)	6 in. to 12 in.	6-7/16 in. to 12-7/16 in.	
14 x 14 (4,3 x 4,3)	14 (4,3)	15 (56,8)	12.8 (0,88)			
16 x 16 (4,9 x 4,9)	16 (4,9)	18 (68,1)	18.4 (1,27)			
16 x 18 (4,9 x 5,5)	16 (4,9)	22 (83,3)	27.4 (1,89)			

**TABLE A
WET PIPE SYSTEM
SERIES LFII RESIDENTIAL CONCEALED HORIZONTAL SIDEWALL SPRINKLER
NFPA 13D, 13R, AND 13 HYDRAULIC DESIGN CRITERIA**

Design Criteria

The Series LFII Concealed Horizontal Sidewall Sprinkler is UL and C-UL Listed for installation in accordance with the following criteria.

Residential Sprinkler Design Guide
When conditions exist that are outside the scope of the provided criteria, refer to the Residential Sprinkler Design Guide TFP490 for the manufacturer's recommendations that may be acceptable to the local authority having jurisdiction.

Ceiling Types
Smooth flat horizontal, beamed, or sloped, in accordance with the 2019 Edition of NFPA 13D, 13R, or 13 as applicable.

Hydraulic Design (NFPA 13D and 13R)

For systems designed to NFPA 13D or NFPA 13R, the minimum required sprinkler flow rates are given in Table A as a function of temperature rating and the maximum allowable coverage areas. The sprinkler flow rate is the minimum required discharge from each of the total number of "design sprinklers" as specified in NFPA 13D or NFPA 13R.

Hydraulic Design (NFPA 13)

For systems designed to NFPA 13, the number of design sprinklers is to be the four most hydraulically demanding sprinklers. The minimum required discharge from each of the four sprinklers is to be the greater of the following:

- The flow rates given in Table A as a function of deflector to ceiling distance and the maximum allowable coverage area.
- A minimum discharge of 0.1 gpm/ft² over the "design area" comprised of the four most hydraulically demanding sprinklers for actual coverage areas protected by the four sprinklers.

Obstruction to Water Distribution

Sprinklers are to be located in accordance with the obstruction rules of NFPA 13D, 13R, and 13 as applicable for residential sprinklers as well as with the obstruction criteria described within the TYCO Technical Data Sheet TFP490.

Operational Sensitivity

In addition the top-of-deflector-to-ceiling distance is to be within the range (see Table A) being hydraulically calculated.

Sprinkler Spacing

The minimum spacing between sprinklers is 8 ft (2,4 m). The maximum spacing between sprinklers cannot exceed the width of the coverage area (see Table A) being hydraulically calculated, for example, maximum 12 ft for a 12 ft x 12 ft coverage area, or 16 ft for a 16 ft x 18 ft coverage area.

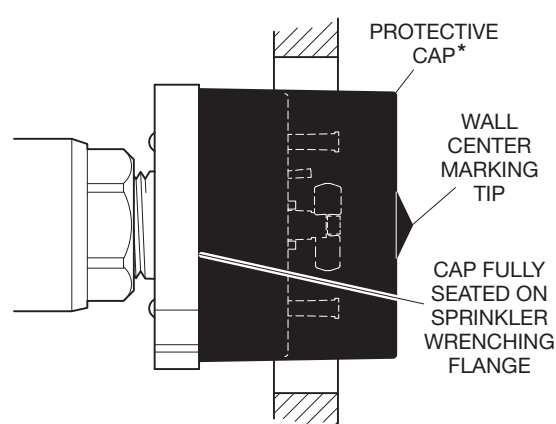
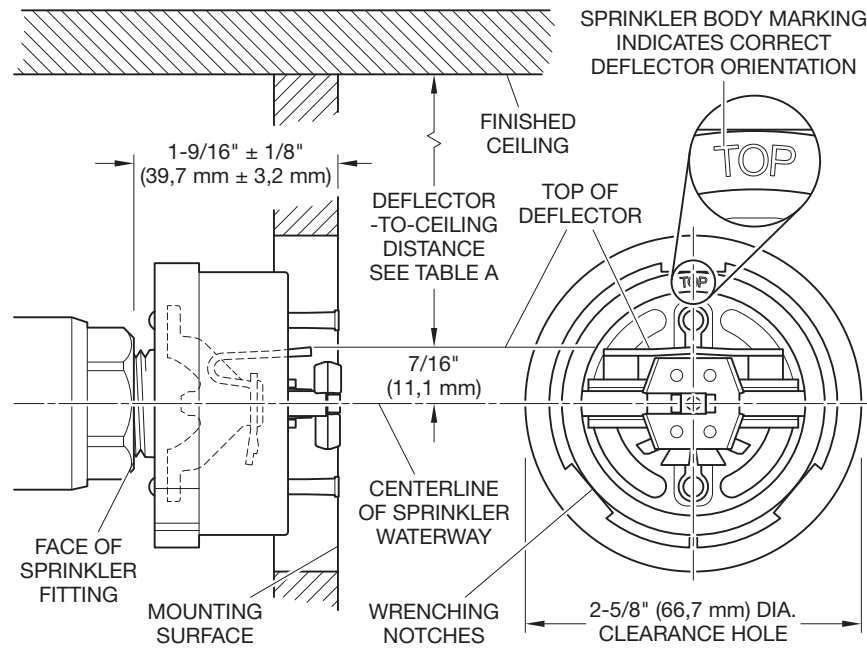

*** NOTICE**

Factory-assembled protective cap to remain attached during sprinkler installation.

Temporarily remove to verify correct deflector orientation and reinstall during wall finishing.

Remove only after installation is complete to allow proper sprinkler performance.

LDPE cap may be recycled accordingly.

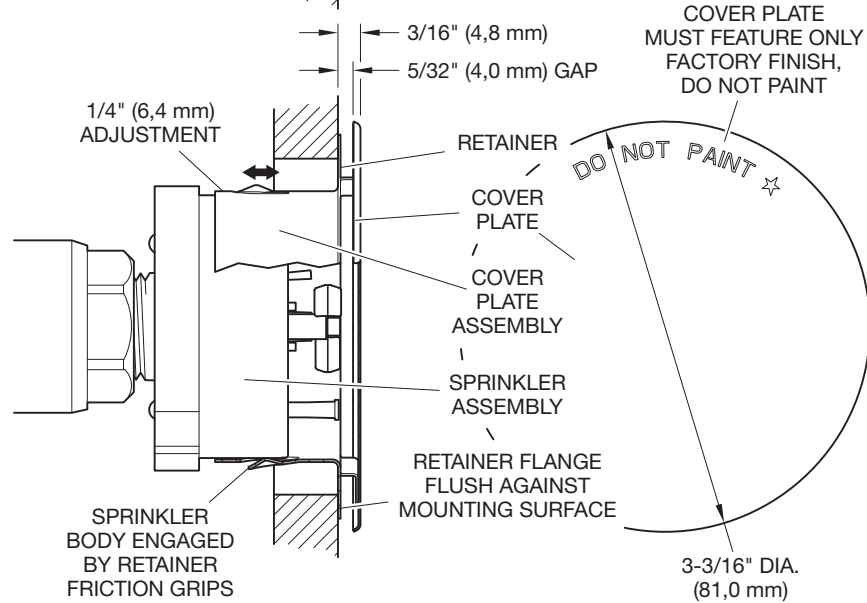

FIGURE 3
SERIES LFII RESIDENTIAL CONCEALED HORIZONTAL SIDEWALL SPRINKLER
INSTALLATION CRITERIA

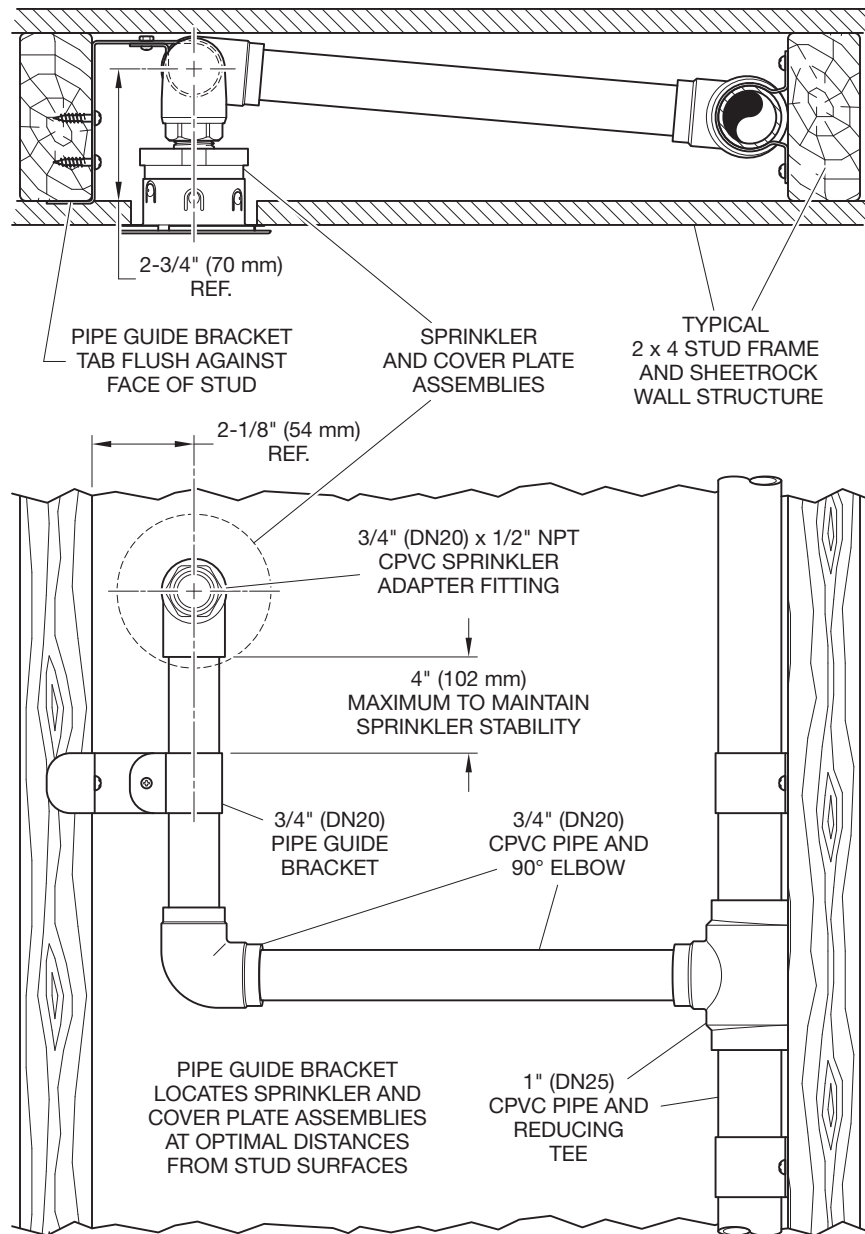

FIGURE 4
SERIES LFII RESIDENTIAL CONCEALED HORIZONTAL SIDEWALL SPRINKLER
PIPE GUIDE BRACKET WALL INSTALLATION

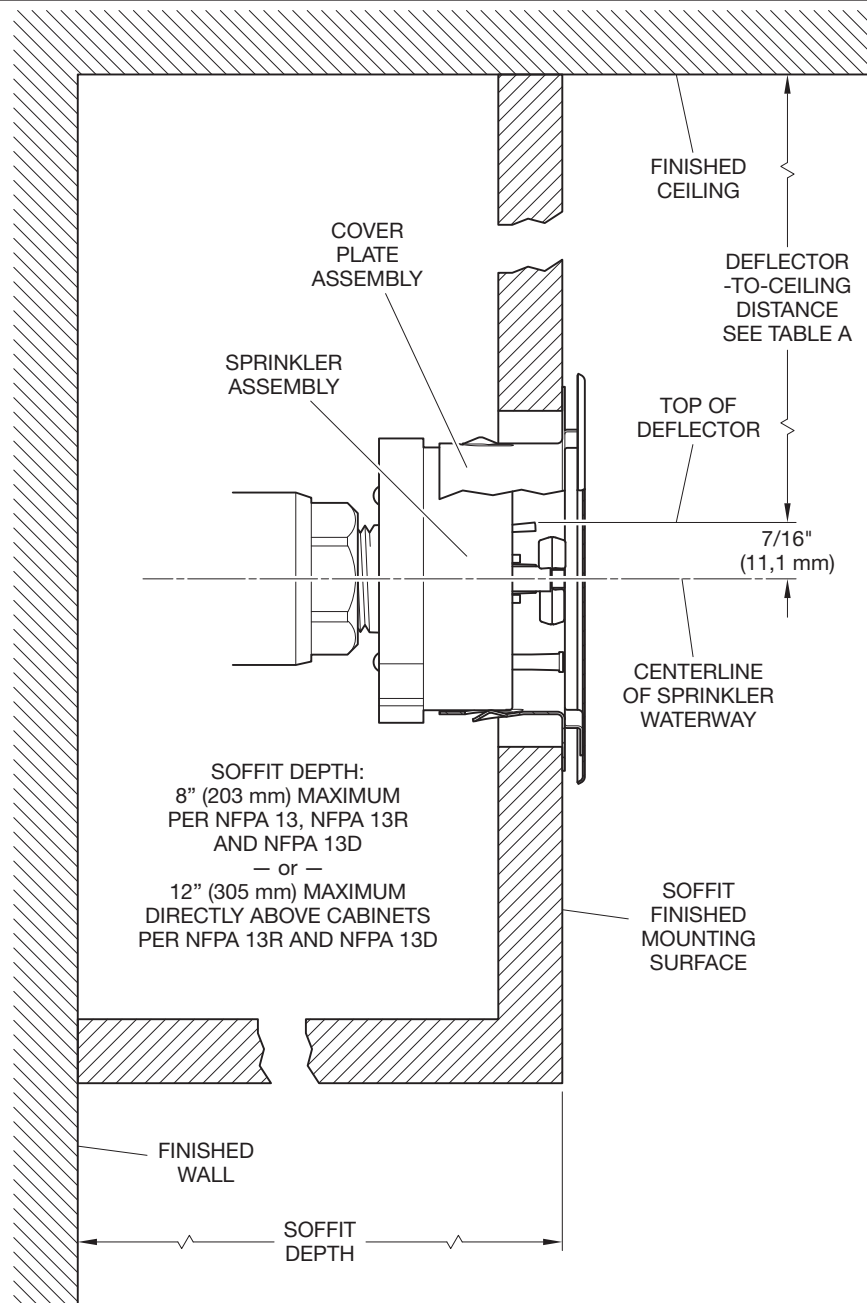

FIGURE 5
SERIES LFII RESIDENTIAL CONCEALED HORIZONTAL SIDEWALL SPRINKLER
SOFFIT INSTALLATION CRITERIA

Installation

The Series LFII Concealed Horizontal Sidewall Sprinkler must be installed in accordance with this section.

General Instructions

Damage to the fusible link assembly during installation can be avoided by handling the sprinkler by the body only. Do not apply pressure to the fusible link assembly.

A leak-tight ½ in. NPT sprinkler joint should be obtained by applying a minimum to maximum torque of 7 to 14 lb-ft (9,5 to 19,0 N·m).

Higher levels of torque can distort the sprinkler inlet with consequent leakage or impairment of the sprinkler.

Do not attempt to compensate for insufficient adjustment in a Cover Plate by under- or over-tightening the sprinkler. Re-adjust the position of the sprinkler fitting to suit.

RAPID RESPONSE Series LFII Residential Concealed Horizontal Sidewall Sprinklers

The Series LFII Concealed Horizontal Sidewall Sprinkler must be installed in accordance with the following instructions.

Step 1. To ensure that the sprinkler is located the correct distance from the face of the surface wall, use the provided pipe guide, included with each sprinkler TY2324, and attach it to the ¾ in. CPVC pipe and the 2 x 4 inside the wall, as shown in Figure 4. The sprinkler must only be installed with its centerline perpendicular to the back wall and parallel to the ceiling. Use a W-Type 37 Wrench for installation. The wrench contains an outer flat surface reference that correlates with the sprinkler deflector orientation. The word "UP" on the installation wrench is to face towards the ceiling to ensure proper alignment.

Note: The TYCO RAPID RESPONSE Sprinkler can be installed in both CPVC and standard steel piping/fittings.

NOTICE

Do not remove the Protective Cap until the Cover Plate Assembly is installed and/or the fire protection sprinkler system is ready to be placed in service.

Step 2. With pipe thread sealant applied to the sprinkler threads, align the sprinkler alignment slot with the W-Type 37 Sprinkler Wrench alignment slot and engage by inserting the sprinkler into the wrench cavity, fully seating the wrench shoulder against the sprinkler wrenching flange. Hand tighten the sprinkler into the sprinkler fitting.

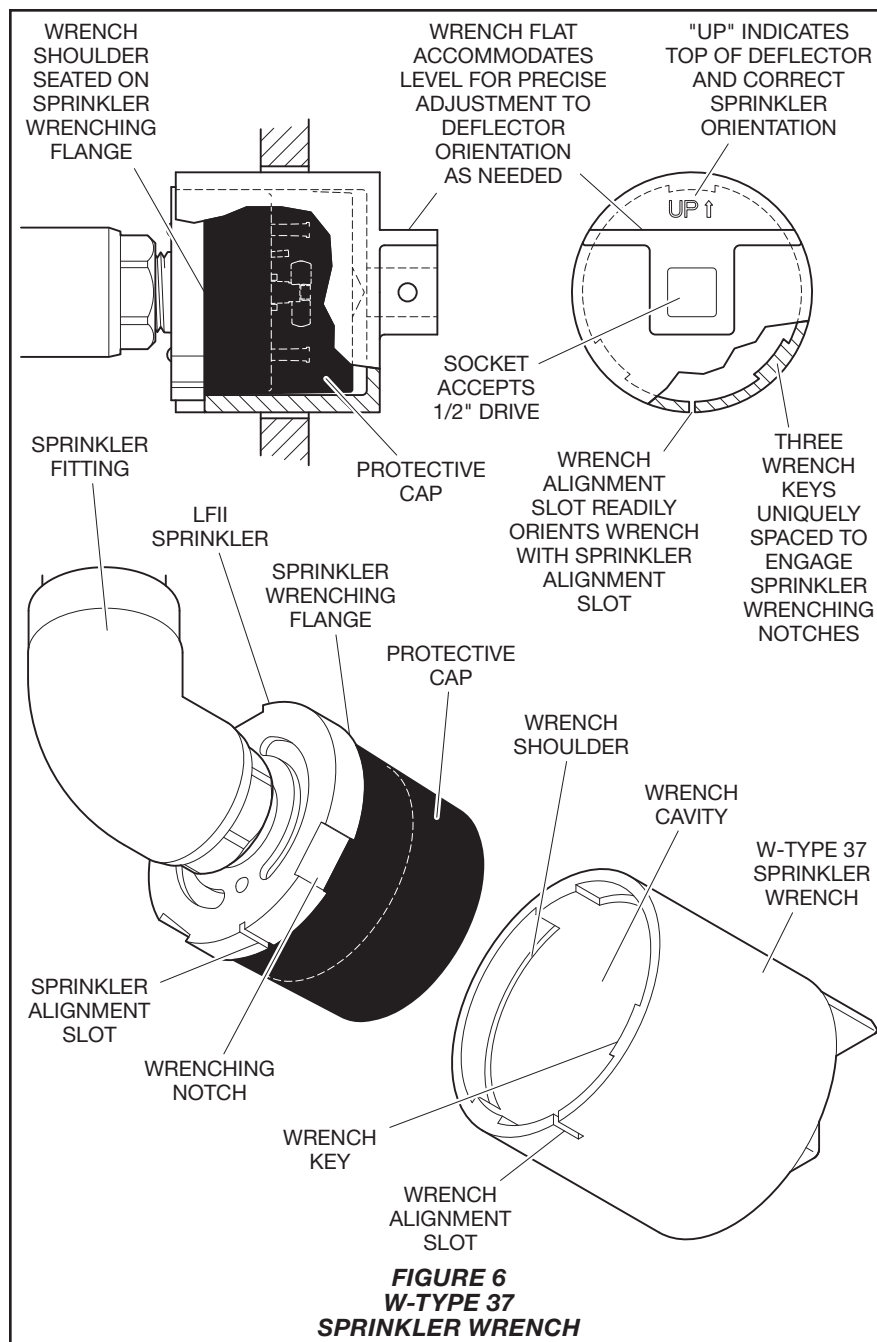

FIGURE 6
W-TYPE 37
SPRINKLER WRENCH

Step 3. Once hand tight, attach an ½ in. (12,7 mm) drive to the sprinkler wrench and wrench tighten to ensure proper seal and alignment.

Step 4. After the wall has been completed with the nominal 2-5/8 in. (66,7 mm) diameter clearance hole and in preparation for installing the Cover Plate Assembly, remove and discard the Protective Cap. If the sprinkler has been damaged in any way including accidental over spray from finishing the wall, replace the entire sprinkler.

NOTICE

The sprinkler must be installed in neutral or negative pressure plenums only.

Step 5. Push the Cover Plate Assembly onto the sprinkler, and as necessary, make the final adjustment of the Cover Plate with respect to the wall by pushing the Cover Plate Assembly until the retainer flange is flush against the wall. If it becomes necessary to remove the Cover Plate, it can be removed by gently pulling the Cover Plate Assembly way from the sprinkler body.

Note: A Cover Plate Assembly not adequately engaging the sprinkler body,

that is not securely attached, indicates the sprinkler is positioned at a distance from the mounting surface greater than is described in Figure 3. A Cover Plate Assembly fully engaged on the sprinkler body while the retainer flange is not in contact with the wall indicates the sprinkler is positioned at a distance from the mounting surface lesser than described in Figure 3. If either condition is encountered when attempting to install the Cover Plate Assembly, the sprinkler fitting must be repositioned.

Care and Maintenance

The Series LFII Concealed Horizontal Sidewall Sprinkler must be maintained and serviced in accordance with this section.

Before closing a fire protection system main control valve for maintenance work on the fire protection system that it controls, obtain permission to shut down the affected fire protection systems from the proper authorities and notify all personnel who may be affected by this action.

The owner is responsible for the inspection, testing, and maintenance of their fire protection system and devices in compliance with this document, as well as with the applicable standards of the NATIONAL FIRE PROTECTION ASSOCIATION, for example, NFPA 25, in addition to the standards of any authorities having jurisdiction. Contact the installing contractor or sprinkler manufacturer regarding any questions.

Automatic sprinkler systems are recommended to be inspected, tested, and maintained by a qualified Inspection Service in accordance with local requirements and/or national codes.

When properly installed, there is a nominal 5/32 in. (4,0 mm) air gap between the lip and the Cover Plate and the wall, as shown in Figure 3. This air gap is necessary for the proper operation of the sprinkler. If the wall is to be repainted after installation of the sprinkler, care must be exercised to ensure that the new paint does not seal off any of the air gap.

Factory painted cover plates must not be repainted. They should be replaced if necessary, by factory painted units. Non-factory applied paints may adversely delay or prevent sprinkler operation in the event of a fire.

If removal of the Cover Plate is necessary relative to the enclosure, be conscious not to be too forceful, where separation may result.

Sprinklers that are found to be leaking or exhibiting visible signs of corrosion must be replaced.

Automatic sprinklers must never be painted, plated, coated, or otherwise altered after leaving the factory. Modified sprinklers must be replaced.

Care must be exercised to avoid damage to the sprinklers - before, during, and after installation. Sprinklers damaged by dropping, striking, wrench twist/slippage, or the like, must be replaced.

If a sprinkler must be removed, do not reinstall it or a replacement without reinstalling the Cover Plate Assembly. If a Cover Plate Assembly becomes dislodged during service, replace it immediately.

Sprinklers that are found to be leaking or exhibiting visible signs of corrosion must be replaced.

Automatic sprinklers must never be painted, plated, coated or otherwise altered after leaving the factory. Modified or over heated sprinklers must be replaced.

Care must be exercised to avoid damage to the sprinklers before, during, and after installation. Sprinklers damaged by dropping, striking, wrench twist/slippage, or the like, must be replaced.

If a sprinkler must be removed, do not reinstall it or a replacement without reinstalling the Cover Plate Assembly. If a Cover Plate Assembly becomes dislodged during service, replace it immediately.

Limited Warranty

For warranty terms and conditions, visit www.tyco-fire.com.

Ordering Procedure

Contact your local distributor for availability. When placing an order, indicate the full product name and Part Number (P/N).

Sprinkler Assembly
Specify: Series LFII (TY2324), K=4.2, Residential Horizontal Sidewall Sprinkler, without Cover Plate Assembly, P/N 50-520-1-160

Note: Sprinkler and Cover Plates are separately ordered. See below for Cover Plate ordering information.

Cover Plate Assembly (Separately Ordered)
Specify: Series LFII Concealed Sprinkler Cover Plate Assembly, (specify finish), P/N (specify):

Ivory (RAL1015)	56-204-0-135
Beige (RAL1001)	56-204-2-135
Pure White (RAL9010)*	56-204-3-135
Signal White (RAL9003)**	56-204-4-135
Grey White (RAL9002)	56-204-5-135
Brown (RAL8028)	56-204-6-135
Black (RAL9005)	56-204-7-135
Brushed Brass	56-204-8-135
Brushed Chrome	56-204-9-135
Custom Paint	56-204-X-135

*Eastern Hemisphere sales only
**Previously known as Bright White

Note: All Custom Cover Plates are painted using SHERWIN-WILLIAMS Interior Latex Paint. Contact Johnson Controls Customer Service with any questions related to custom orders.

Sprinkler Wrench
Specify: W-Type 37 Sprinkler Wrench, P/N 56-320-1-015

Pipe Guide Bracket
Pipe Guide Bracket accessory for sprinkler installation adjacent to framing member such as 2 x 4 within wall structure, includes mounting screws.

Specify: Pipe Guide Bracket, P/N 91-520-115