

## Model MRA-1 Manual Reset Actuator Trim Component For DV-5A Automatic Water Control Valves

### General Description

The TYCO Model MRA-1 Manual Reset Actuator is designed for use with the TYCO DV-5A Automatic Water Control Valve. Supplied as a trim component for the DV-5A Valve, the Model MRA-1 Manual Reset Actuator is used to “hydraulically latch” the DV-5A Valve in the tripped position upon activation of the DV-5A (e.g., flowing water into the sprinkler system as in a fire condition). In addition, the Model MRA-1 Manual Reset Actuator is used to provide an external reset feature to allow resetting of the DV-5A Valve after the system is shut-down (e.g. after a fire condition).

#### NOTICE

*The TYCO Model MRA-1 Manual Reset Actuator described herein must be installed and maintained in compliance with this document, as well as with the applicable standards of the NATIONAL FIRE PROTECTION ASSOCIATION (NFPA), in addition to the standards of any other authorities having jurisdiction. Failure to do so may impair the integrity of this device.*

*The owner is responsible for maintaining their fire protection system and devices in proper operating condition. Contact the installing contractor or product manufacturer with any questions.*

#### IMPORTANT

*Refer to Technical Data Sheet TFP2300 for warnings pertaining to regulatory and health information.*

### Technical Data

#### Approvals

The TYCO Model MRA-1 Manual Reset Actuator forms a part of the overall approvals given in the applicable technical data sheets for the TYCO DV-5A Automatic Water Control Valve.

#### Maximum Pressure

300 psi (20,7 bar)

#### Assembly

|                    |                 |
|--------------------|-----------------|
| Body .....         | Bronze          |
| Cover .....        | Bronze          |
| Plunger/Seal ..... | Bronze/EPDM     |
| Spring .....       | Stainless Steel |
| Reset Knob .....   | Phenolic/Bronze |

### Operation

The TYCO Model MRA-1 Manual Reset Actuator, when depressurized and prior to setting the DV-5A Valve, is in the “open-tripped” position, and Ports A, B, C, D, and E are at atmospheric pressure (Ref. Figure 1) and in communication.

When resetting the DV-5A, the Diaphragm Chamber Supply Control Valve (Ref. Figure 2) is opened and the water flows into the MRA-1 through Port A. Subsequently, water flows to the DV-5A Diaphragm Chamber through port B; to the Pressure Gauge at Port C; and to the normally closed release devices (solenoid valve, dry pilot actuator, or manual control station) connected to Port D. Water will drain from Port E.

During the reset procedure, when unaerated water is observed to be discharging from Port E to drain, the Reset Knob (Ref. Figure 3) is depressed to seat the Plunger/Seal and allow the Plunger/Seal Chamber to pressurize.

Seating the Plunger Seal will close off flow to port E (Ref. Figures 1 and 2), and when the Pressure Gauge indicates at least 15 psi (1 bar), the Reset Knob no longer requires manual depressing. The MRA-1 Manual Reset Actuator is then in the “closed-set” position, and the DV-5A Diaphragm Chamber will continue to completely pressurize permitting the DV-5A to continue with the setting process.



With the MRA-1 set, Ports A, B, C, and D are in communication with each other and the pressure is indicated on the Pressure Gauge at Port C. Port E is open to the atmosphere.

In the event of a fire or testing of the DV-5A Valve, a releasing device (solenoid valve, dry pilot actuator, or manual control station) trips the MRA-1 by releasing pressure from the Plunger/Seal Chamber allowing the Spring to lift the Plunger Seal from “closed-set” to “open-trip”. Tripping the MRA-1 releases water from the DV-5A Diaphragm Chamber through the MRA-1 Manual Reset Actuator, which in turn allows the DV-5A to trip open for flow of water to the system piping.

Because of the restriction between Port A and the Plunger/Seal Chamber, the Plunger/Seal Chamber experiences an instantaneous pressure drop allowing the spring load to push the Plunger Seal off of its seat and open the MRA-1. With the MRA-1 “open”, water is constantly drained through Port E faster than it can be replenished through the restriction in the line supplying Port A. In the “open” position, the MRA-1 keeps the DV-5A Valve in the tripped open condition until the water supply is shut-off, as is the case after a fire or inspection testing. Consequently, even if a release device inadvertently closes during a fire condition, the continuous venting of the DV-5A Diaphragm Chamber through Port E will essentially “hydraulically latch” the DV-5A in the tripped open position.

## Installation

The TYCO Model MRA-1 Manual Reset Actuator is provided as a trim component for TYCO DV-5A Automatic Water Control Valves. The MRA-1 must be installed in accordance with the specific instructions provided with TYCO Deluge Valve technical data sheets.

## Care and Maintenance

The TYCO Model MRA-1 Manual Reset Actuator must be inspected in accordance with instructions provided with the TYCO DV-5A Automatic Water Control Valve technical data sheets, in addition to any specific requirements of the NATIONAL FIRE PROTECTION ASSOCIATION. Any impairment must be immediately corrected.

Before closing a fire protection system control valve for inspection or maintenance work on the fire protection system which it controls, permission to shut down the affected fire protection systems must first be obtained from the proper authorities and all personnel who may be affected by this action must be notified.

The owner is responsible for the inspection, testing, and maintenance of their fire protection system and devices in compliance with this document, as well as with the applicable standards of the NFPA (e.g., NFPA 25), in addition to the standards of any authority having jurisdiction. Contact the installing contractor or product manufacturer with any questions.

Automatic sprinkler systems are recommended to be inspected, tested, and maintained by a qualified Inspection Service.

After placing a fire protection system in service, notify the proper authorities and advise those responsible for monitoring proprietary and/or central station alarms.

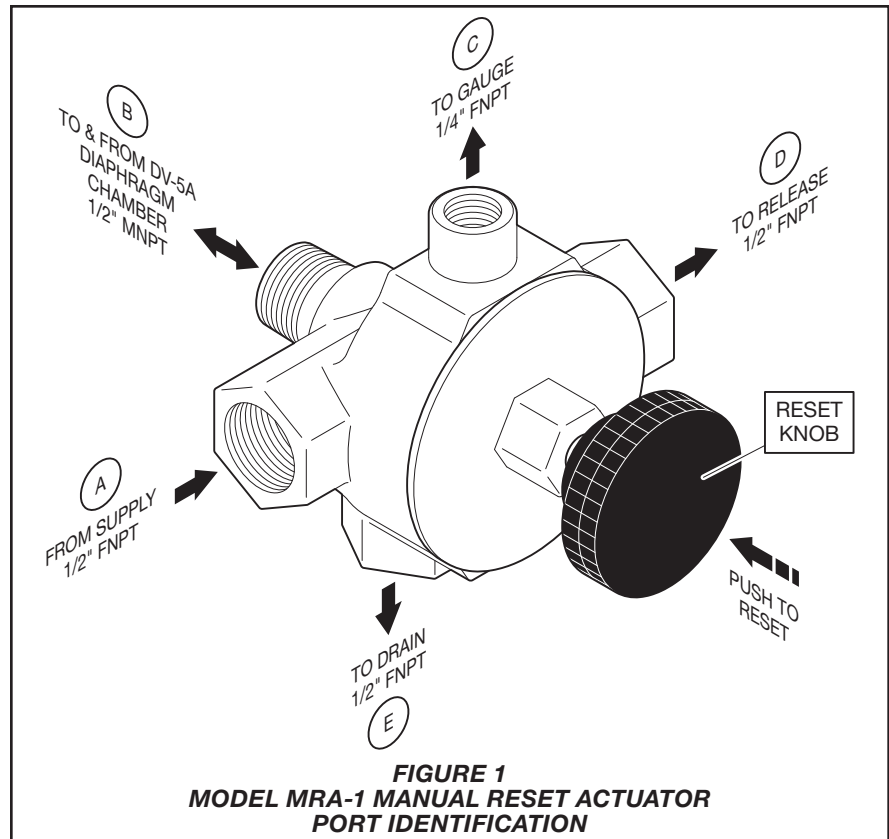

### Inspection Procedure

The TYCO Model MRA-1 Manual Reset Actuator must be inspected quarterly in accordance with the following instructions, and any impairment must be corrected by replacing the MRA-1.

**Step 1.** When in the set “closed” position, there should not be any water leakage from Port E to the drain.

**Step 2.** During the quarterly test of the DV-5A Valve release (solenoid valve, dry pilot actuator, or manual control station), verify the MRA-1 “opens” as evidenced by water discharging from Port E to drain and the loss of pressure on the Pressure Gauge.

**Step 3.** Reset the actuated release device and verify that the MRA-1 remains “open” as evidenced by continued water discharging from Port E to drain and the loss of pressure on the Pressure Gauge.

**Step 4.** Refer to the applicable TYCO DV-5A Valve technical data sheets for resetting instructions.

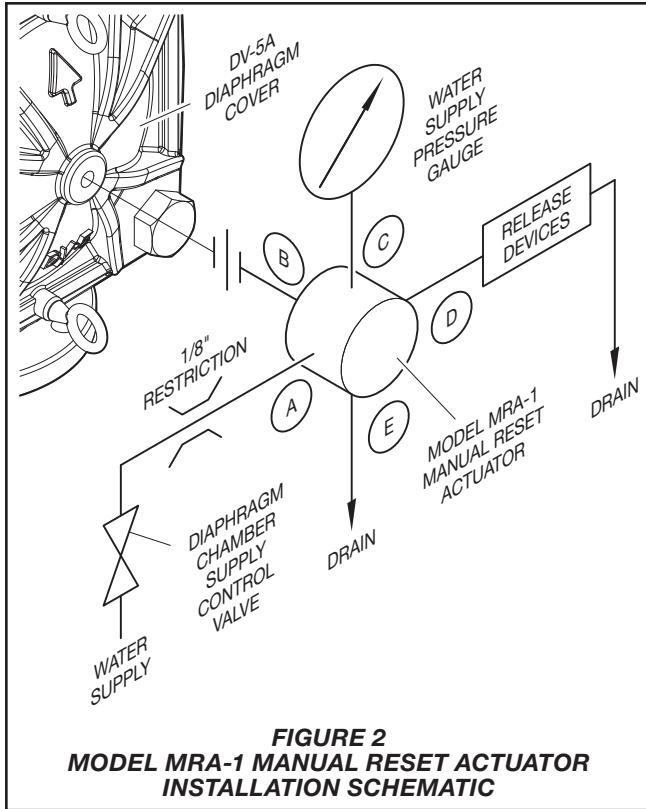

## Limited Warranty

For warranty terms and conditions, visit [www.tyco-fire.com](http://www.tyco-fire.com).

## Ordering Procedure

The TYCO Model MRA-1 Manual Reset Actuator is provided as a trim component for the TYCO DV-5A Automatic Water Control Valve. Orders for replacement Model MRA-1 Manual Reset Actuator must include a full description and Part Number (P/N).

Specify: Model MRA-1 Manual Reset Actuator, P/N 54-500-1-000.

