

Series MJC Multiple Jet Controls DN20, DN25, DN40, and DN50, 12 bar BSPT Inlet & Outlets Threads

General Description

The TYCO Series MJC Multiple Jet Controls are control valves with self-contained heat actuating units. Available in DN20 through DN50 pipe sizes, they are designed for use as the system control valve for fire protection systems of limited size, where the MJC's are located within the protected area. Upon operation, the MJC's permit a flow of extinguishing medium (usually water) through open spray devices, such as nozzles or non-automatic (open) sprinklers.

The MJC's are typically used as an auxiliary deluge valve to control the flow of water to specific areas within a larger wet pipe, dry pipe, or deluge system. As such they can be used with supply piping from either a wet pipe system (Figure 1) or a dry pipe or deluge system (Figure 2).

In all cases, waterflow alarms are provided by the main automatic control valve for the system that supplies the supply line to the Series MJC Multiple Jet Controls (e.g., alarm valves, dry pipe valves, or deluge valves).

For smaller design areas, the MJC's serve as an individual heat activation point and control valve (Figures 1A and 2A). For larger design areas, the MJC's can be set up to provide multiple heat activation points, while still providing water flow through all discharge points with the activation of only one MJC

IMPORTANT

Refer to Technical Data Sheet TFP2300 for warnings pertaining to regulatory and health information.

Always refer to Technical Data Sheet TFP700 for the "INSTALLER WARNING" that provides cautions with respect to handling and installation of sprinkler systems and components. Improper handling and installation can permanently damage a sprinkler system or its components and cause the sprinkler to fail to operate in a fire situation or cause it to operate prematurely.

(Figures 1B and 2B). In this example, water flows through the non-operated MJC from outlet to outlet (Figure 9).

Features

- Available in four pipe sizes
- Fully automatic using proven frangible glass bulb as the heat detection medium
- Installed upright (heat sensitive bulb at top) for water supplies from either a dry pipe or deluge system or pendant (heat sensitive bulb at bottom) for a water supply from a wet system
- Defined areas of protection to provide total coverage of specific zones
- DN25, DN40, and DN50 provided with protective guard
- DN25, DN40, and DN50 has option for thermoelectric actuation that can be used in combination with highly sensitive detection systems and/or manual electric actuation

NOTICE

The TYCO Series MJC Multiple Jet Controls described herein must be installed and maintained in compliance with this document, as well as with the applicable standards recognized by the Approval agency, in addition to the standards of any authorities having jurisdiction. Failure to do so may impair the performance of these devices.

The owner is responsible for maintaining their fire protection system and devices in proper operating condition. Contact the installing contractor or product manufacturer with any questions.



Technical Data

Approvals

LPCB Approved
(Refer to Tables A, B, C, and D.)

Working Pressure Range

1,4 to 12,0 bar

Temperature Ratings

Refer to Tables A, B, C, and D.

Pressure Loss

Refer to Graphs A and B.

Construction

The TYCO Series MJC Multiple Jet Controls are manufactured from cast iron, leaded gun metal, copper, brass, nickle silver, and glass (Figures 3, 4, 5, and 6).

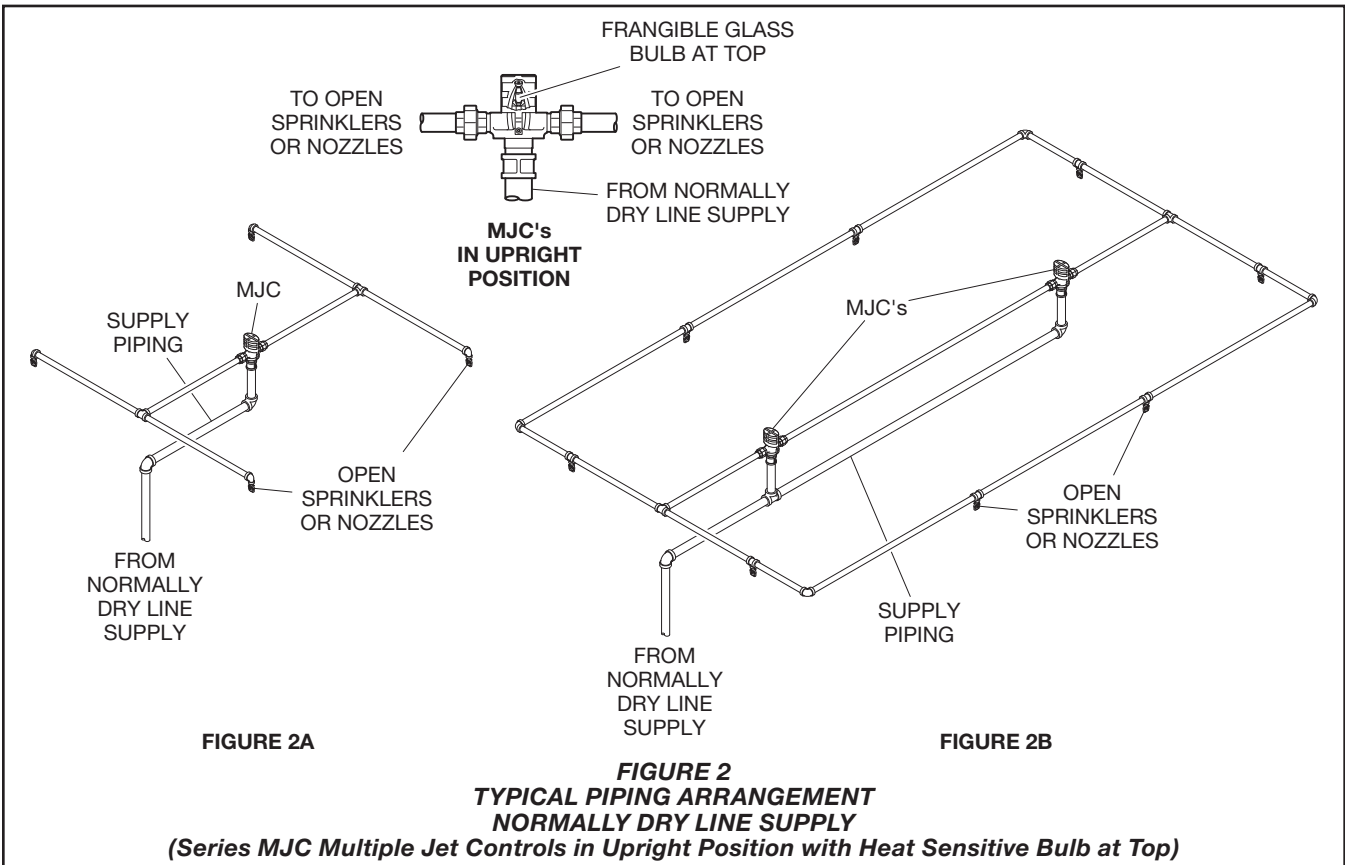
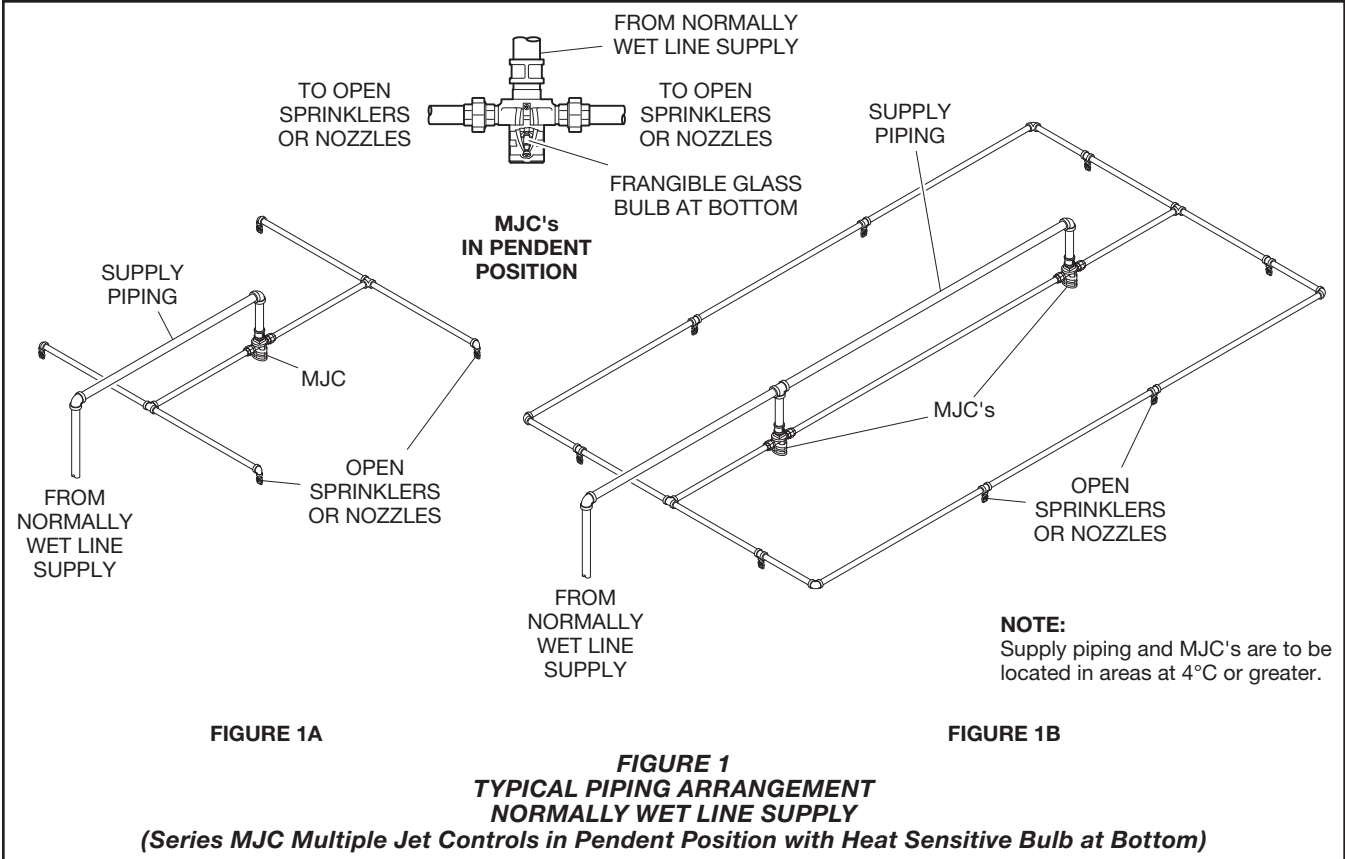

Design Criteria

Ambient Temperature

For normally wet pipe systems, do not install Series MJC Multiple Jet Controls in areas that are subject to freezing.

Water Supply

Water should be free of particles and/or site debris. Do not use sea or brackish water.

Piping Arrangements

A “wet supply line” is typically being supplied from an alarm valve (Figure 1) and the “dry supply line” is typically being supplied from either a dry pipe valve or deluge valve (Figure 2). Water-flow alarms, system pressure gauges, and flow test capability are therefore provided by the alarm, dry pipe, or deluge valve.

Sequence of Operation

- For a wet pipe system supply, water is readily available for flow through the TYCO Series MJC Multiple Jet Controls; however, water is only allowed past the MJCs when the glass bulb in the MJCs is actuated by heat (or the thermoelectric actuator).
- For a dry pipe system supply, operation of the glass bulb in the MJCs when actuated by heat (or the thermoelectric actuator) releases air pressure to permit operation of a dry pipe valve, and then upon operation of the dry pipe valve, water becomes available to flow through the operated MJCs.
- For a deluge system supply and upon operation of the deluge system in response to a dedicated supplemental detection system, water becomes available to the MJCs; however, water is only permitted past the glass bulb in the MJCs if the glass bulb has been actuated by heat (or the thermoelectric actuator).

MJC Installation Position

The MJCs is installed in the upright position (heat sensitive bulb at top as illustrated in Figures 3, 4, 5, and 6) when supplied from a dry pipe or deluge system, or can be installed in the pendent position for a wet pipe system supply (heat sensitive bulb at bottom). For example, in a wet pipe system supply, the MJCs can be installed above a ceiling where its heat sensitive bulb is exposed below the ceiling line. In all cases, the heat sensitive bulb must be in the protected area.

Since the MJCs utilize a thermal sensing element similar to that used for a standard response, standard coverage, frangible glass bulb type sprinkler, the positioning rules for MJCs are the same as standard sprinklers. The heat sensitive bulb to ceiling distance and the area of thermal coverage is based on standard coverage sprinklers as a function of the protected hazard and ceiling construction provided in the applicable standards recognized by the Approval agency for standard coverage sprinklers.

Pressure Loss

Graph A provides the pressure loss versus flow for the MJC configured as a single outlet, and Graph B provides the pressure loss versus flow for the MJC configured for double outlets.

Thermoelectric Actuation

When the Thermoelectric Actuation is applied, the MJCs can be operated automatically as part of a heat/smoke detection system or manually. In either case, suitable control equipment must be selected based on the actuator electrical ratings (Figure 7), the requirements of the customer, and the codes governing installation of electric detection systems. The actuator leads are encased in a flexible conduit (Figure 7) for attachment to an electrical junction box.

When considering the power supply for operating the Thermoelectric Actuators, be aware that the Thermoelectric Actuator, after operation, may be an open circuit, short circuit, or connected to earth. Therefore, it is essential that the power supply be suitably protected.

The recommended storage life (at ambient temperature) for the Thermoelectric Actuator according to the supplier is 10 years (for METRON™ Actuators, refer to DR2005/C1). The working temperature for the Thermoelectric Actuator is -40°C to 100°C (for up to 20 hours provided any temperature greater than 70°C occurs immediately prior to firing). Storage temperature is -30°C to 70°C. After 10 years, the TYCO Series MJC Multiple Jet Controls supplier should be contacted regarding the suitability of the unit for continued use.

Operation

The DN20 TYCO Series MJC Multiple Jet Controls has an inlet connected to either a single or double outlet (Figure 3). For the DN25, DN40, and DN50 MJCs, the central inlet is connected to the double outlets (Figures 4, 5, and 6). Using a cap instead of one of the two unions on the DN25 and DN40

sizes or plugging one of the two unions on the DN50 size will convert a double outlet MJC into a single outlet (Figures 4, 5, and 6). In all cases, the inlet is sealed from the outlet(s), and there is a normally open flow path from the outlet-to-outlet of double outlet MJCs (Figure 9).

In the standby mode, the system supply is sealed by the Diaphragm, that is restrained by the Plunger. In the DN20 assembly, the Plunger is held in position directly by the frangible glass Bulb. In the DN25, DN40, and DN50 assemblies, the Plunger is indirectly held in position by the frangible Bulb and the Lever Arm (Figures 3, 4, 5, and 6).

The frangible glass Bulb contains a liquid that has a freeze-point below -50°C and a high coefficient of expansion. A predetermined amount of vapor is hermetically sealed within the frangible glass Bulb. The liquid naturally expands under the influence of increasing temperature as occurs in the event of a fire, thus increasing the internal pressure within the frangible glass Bulb until the vapor is absorbed and subsequently shatters the frangible glass Bulb allowing the MJCs to open. The temperature at which this happens is determined by the amount of vapor held within the frangible glass Bulb thus the operating temperature of the MJCs can be accurately controlled (Figures 3, 4, 5, and 6).

In the event of a fire the frangible glass Bulb shatters and directly releases the Plunger Valve of the DN20 MJCs or indirectly releases the Plunger by releasing the Lever Arm of the DN25, DN40, or DN50 MJCs. This action in turn allows water pressure to lift the Diaphragm and allow water pressure to pass through to the distribution piping and water distribution devices onto the fire (Figures 3, 4, 5, and 6).

When a Thermoelectric Actuator is utilized (Figure 7), the Thermoelectric Actuator responds to a Control Panel by passing a small electrical current through it causing a pin to be extended, shattering the glass Bulb and actuating the MJC. The Control Panel may be automatically operated by a heat or smoke detection system or manually operated by a manual pull station.

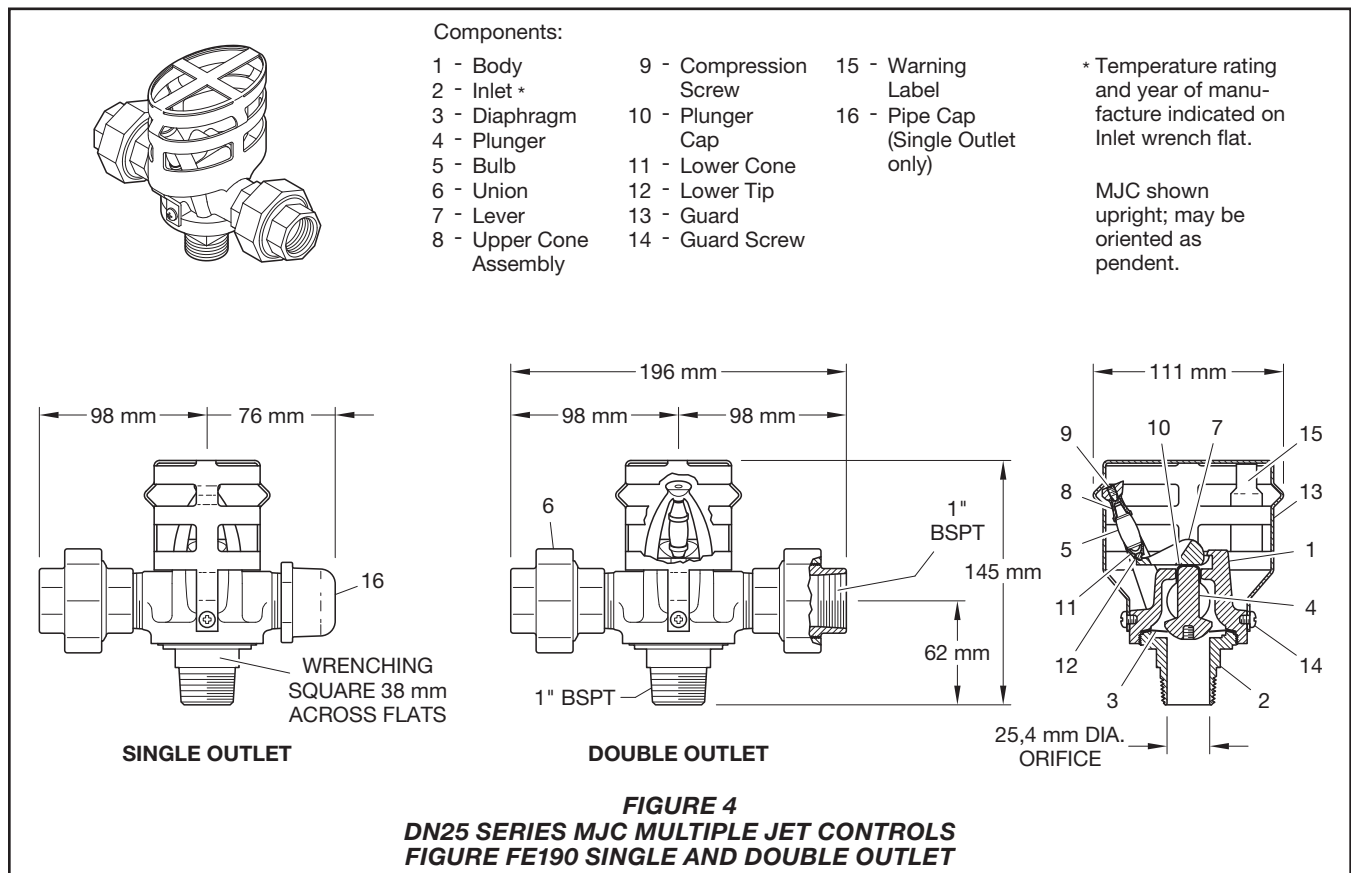
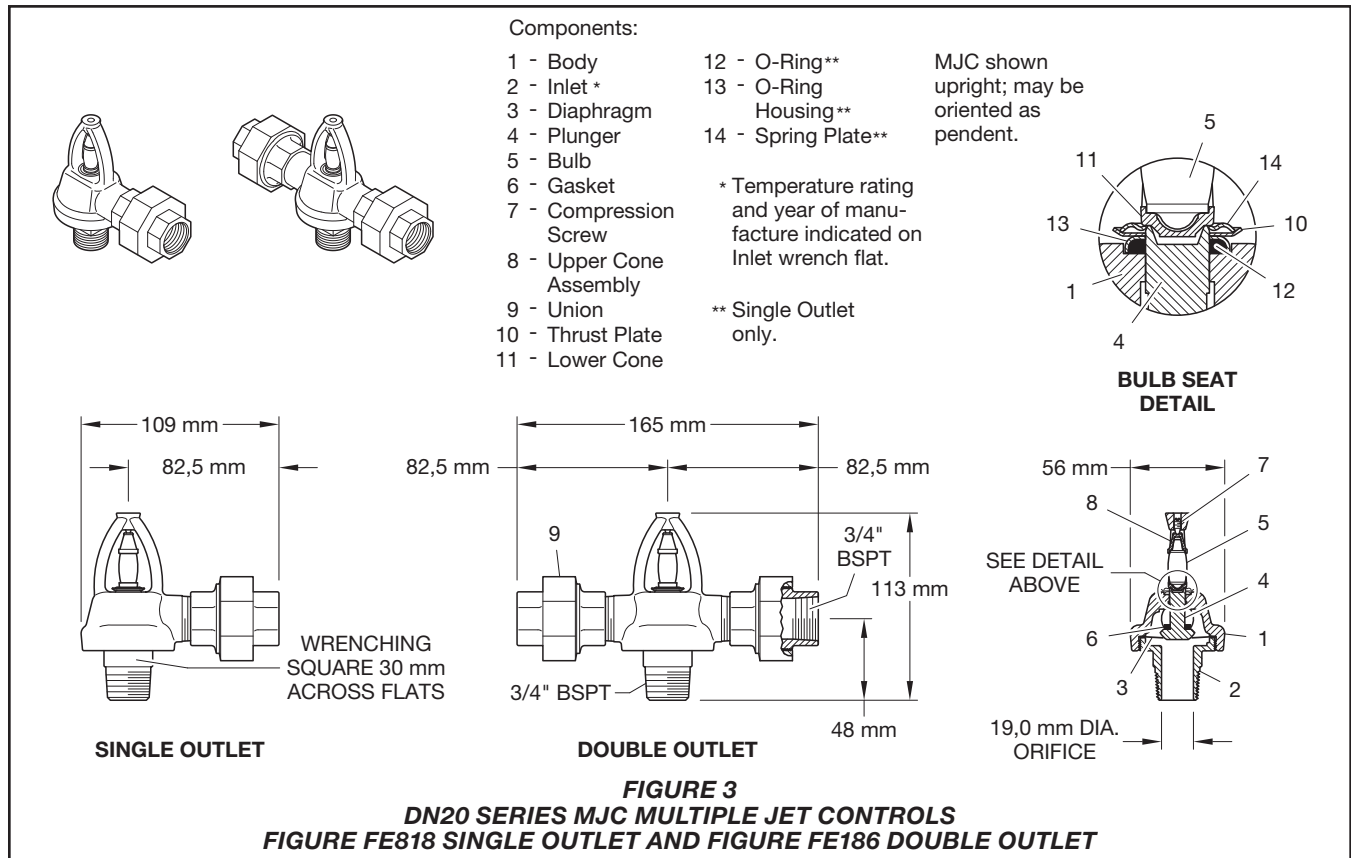

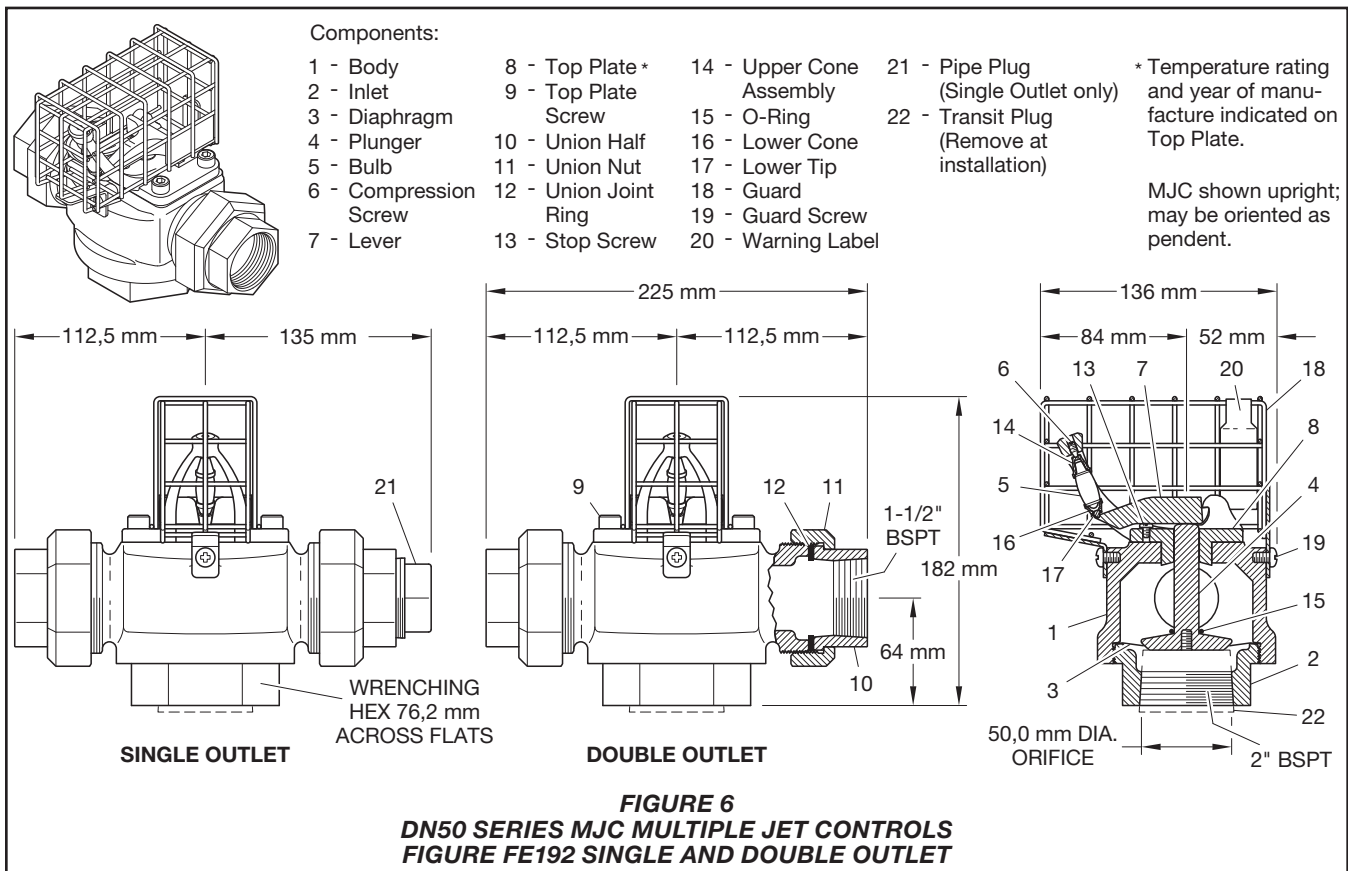
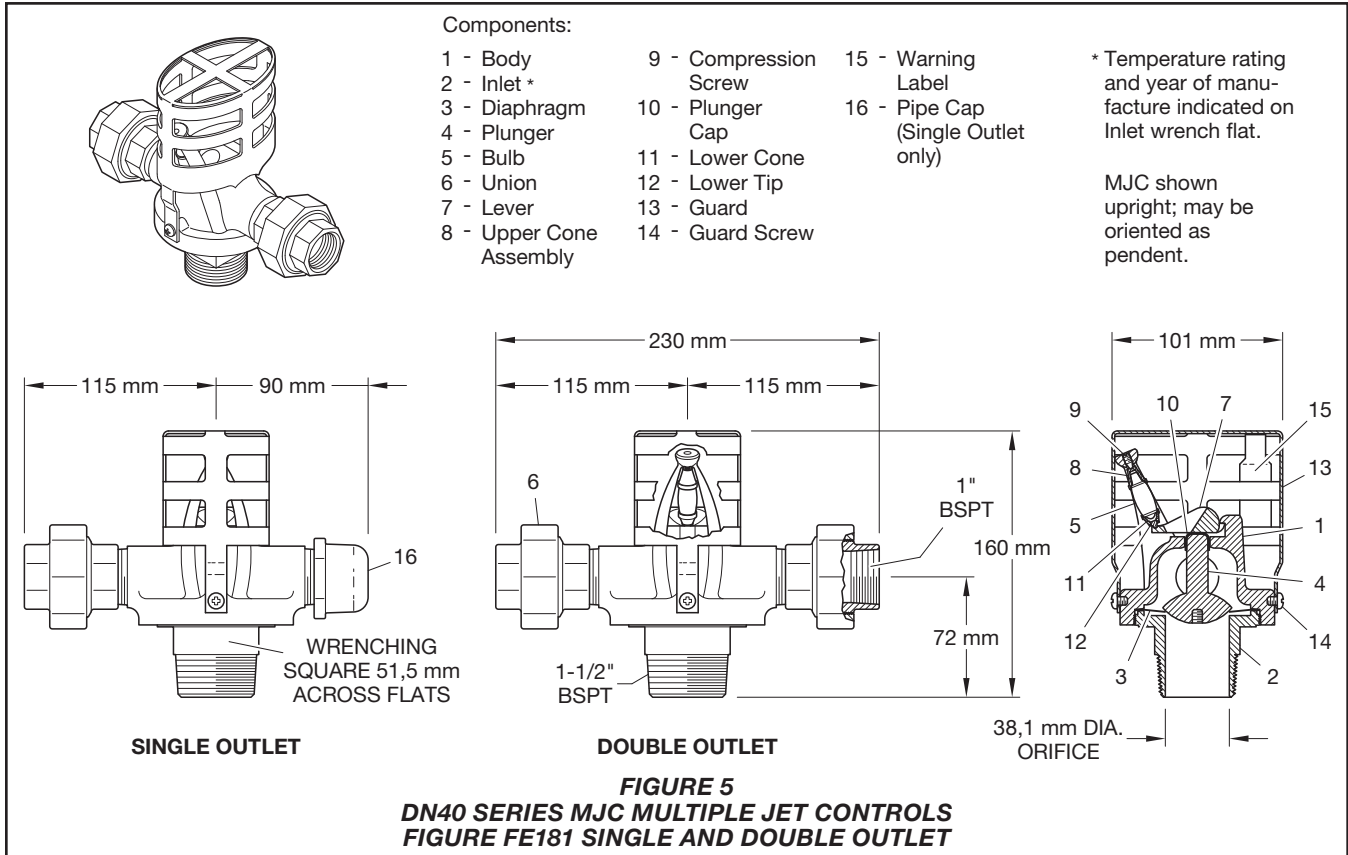

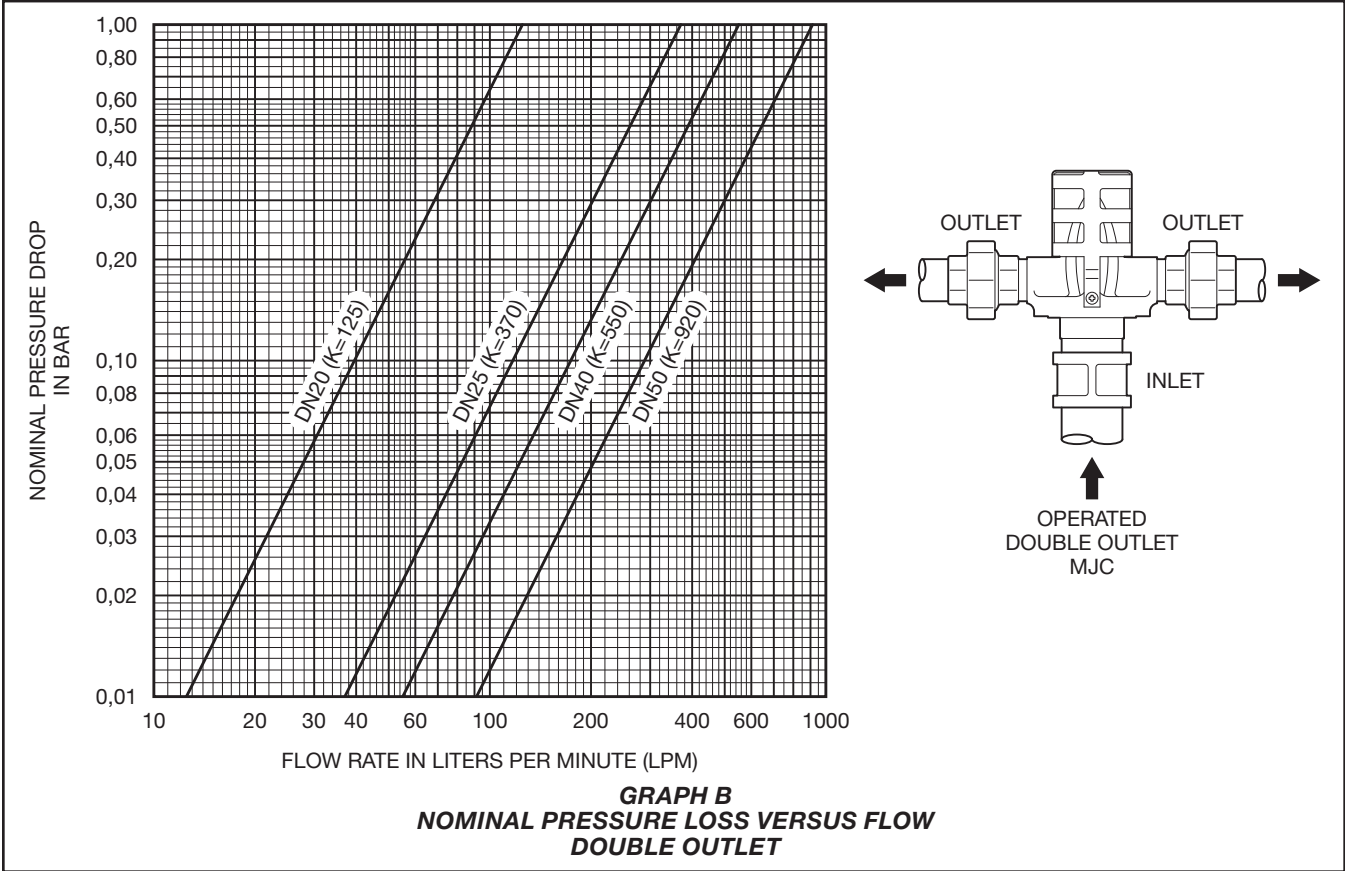
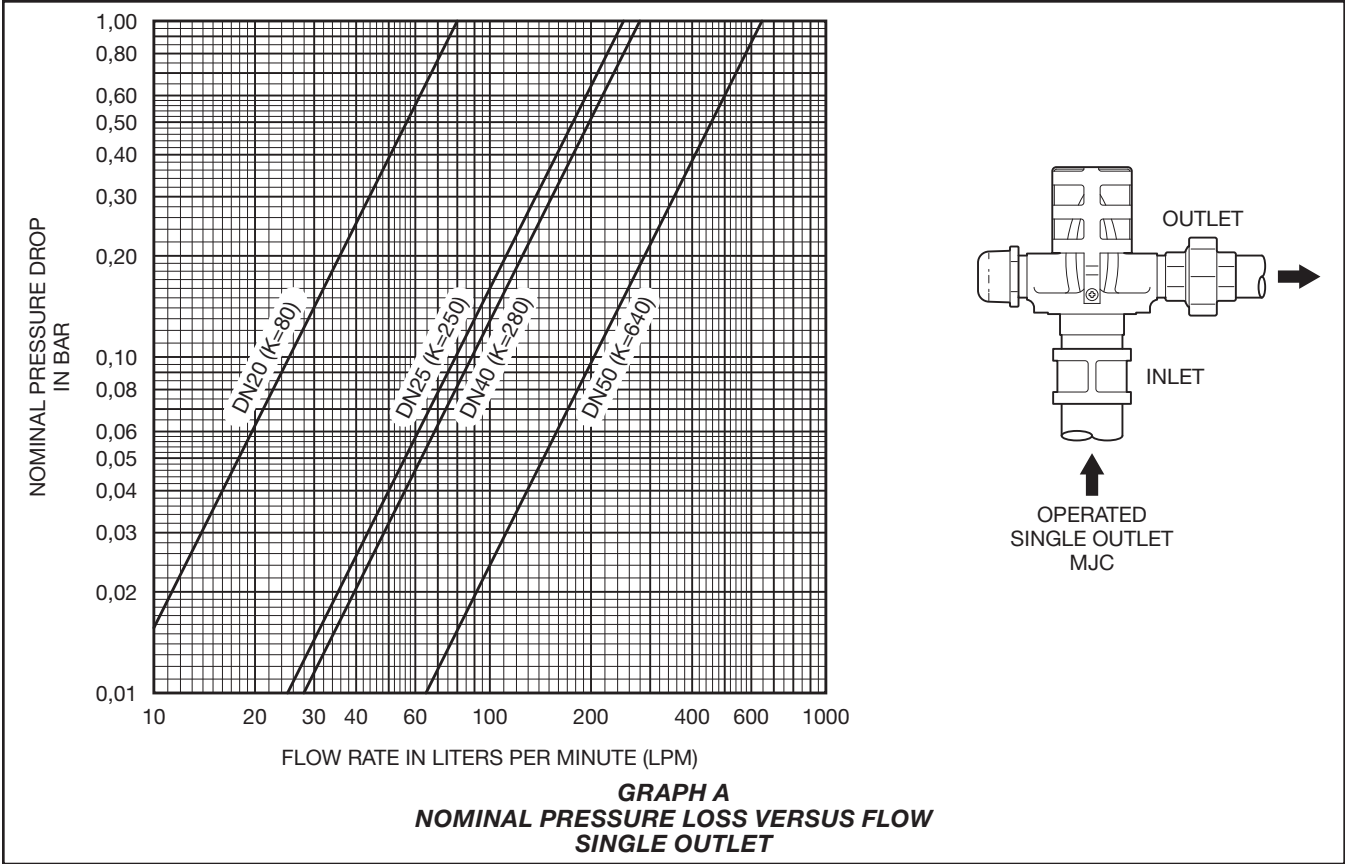

Installation

The TYCO Series MJC Multiple Jet Controls must be installed per the system designer's specifications, which have been based on the information provided in the Design Criteria section.

Exercise care to avoid damage to the MJCs before, during, and after installation. Replace MJCs damaged by dropping, striking, wrench twist/slippage, or the like. Also, replace any MJCs that have a cracked bulb or that has lost liquid from its bulb. The DN25, DN40, and DN50 MJCs are provided with a Notification Tag (Figure 8).

Do not install a TYCO Series MJC Multiple Jet Control if the bulb is cracked or there is a loss of liquid from the bulb. With the MJC held so that the bulb is horizontal, a small air bubble should be present. The diameter of the air bubble is approximately 4,5 mm to 6,4 mm for the 68°C to 141°C temperature ratings.

The MJCs utilize a frangible glass bulb heat sensitive element. Handle with care. The DN25, DN40, and DN50 MJCs are provided with a guard. Removal of the guard voids the manufacturer's warranty.

Care and Maintenance

Before closing a fire protection system main control valve for maintenance work on the fire protection system that it controls, obtain permission to shut down the affected fire protection systems from the proper authorities and notify all personnel who may be affected by this decision.

After a fire, replace all TYCO Series MJC Multiple Jet Controls that have operated with new Series MJC Multiple Jet Controls of the same type and temperature rating. Complete the replacement as soon as possible and after the system is drained. Spare Series MJC Multiple Jet Controls should be kept on site at all times to ensure replacements are installed with minimum of delay.

Never paint, plate, or coat, or otherwise alter MJCs after they leave the factory. Modified MJCs must be replaced. MJCs that have been exposed to corrosive products of combustion, but have not operated, should be replaced if they cannot be completely cleaned by wiping the MJCs with a cloth or by brushing it with a soft bristle brush.

Exercise care to avoid damage to the MJCs before, during, and after installation. MJCs damaged by dropping, striking, wrench twist/slippage, or the like, must be replaced.

Inspection, testing, and maintenance must be performed in accordance with the requirements of the authority having jurisdiction, and any impairment must be immediately corrected. MJCs that are found leaking or exhibiting visible signs of corrosion must be replaced. Also, replace any MJCs that have a cracked bulb or that has lost liquid from its bulb. (Refer to Installation Section.)

Inspections will be limited to a visual inspection as would be performed for automatic sprinklers and at a frequency as required for automatic sprinklers. The TYCO Series MJC Multiple Jet Controls, by the nature of their design, cannot be trip tested.

The owner is responsible for the inspection, testing, and maintenance of their fire protection system and devices in compliance with this document, as well as with the applicable standards of any authorities having jurisdiction. Contact the installing contractor or product manufacturer with any questions.

Automatic sprinkler systems should be inspected, tested, and maintained by a qualified Inspection Service in accordance with local requirements and/or national codes.

Limited Warranty

For warranty terms and conditions, visit www.tyco-fire.com.

Ordering Procedure

Multiple Jet Control

Specify: (specify size and temperature rating) TYCO MJC Series Multiple Jet Control, Figure (specify) Multiple Jet Control (with electrical actuator, if applicable), P/N (specify from Tables A, B, C, or D).

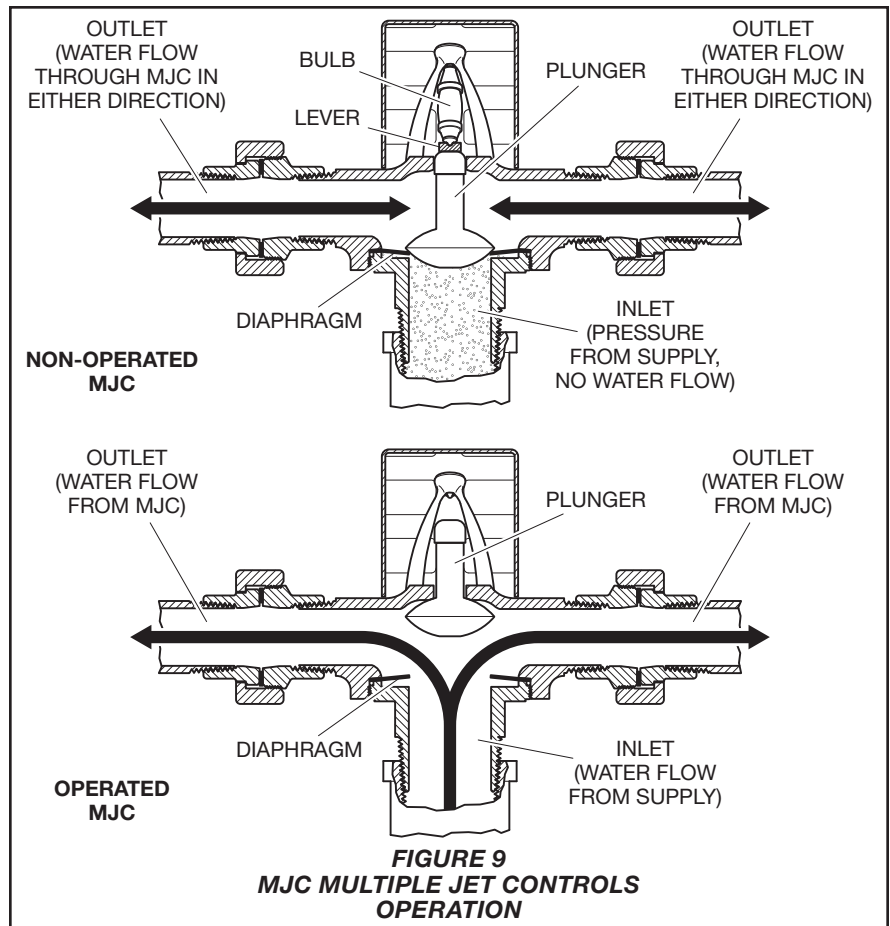
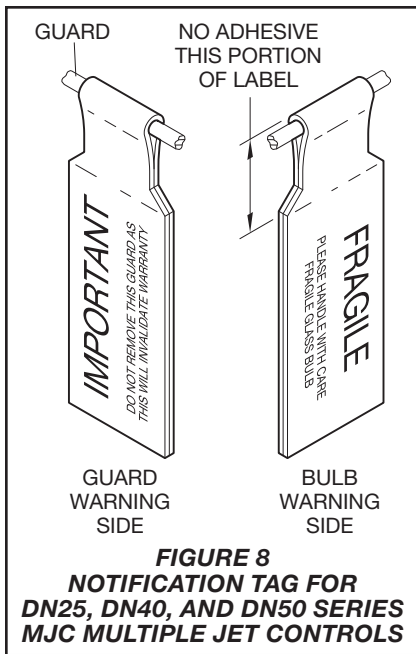
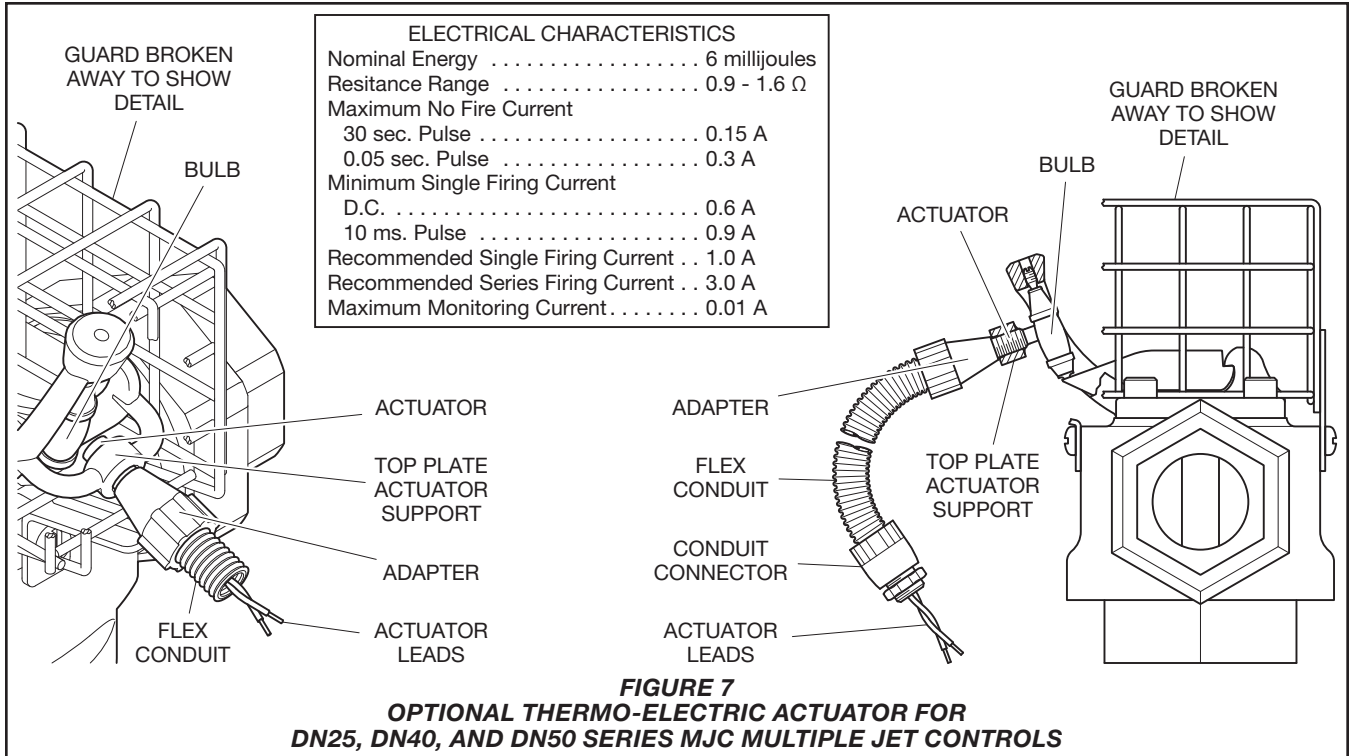

| DN | FIGURE NUMBER and STYLE | APPROVALS | TEMPERATURE RATING | MAXIMUM TEMPERATURE WHERE MJC IS LOCATED | BULB LIQUID COLOR | PART NUMBER |
|----|----------------------------|-----------|--------------------|--|-------------------|-------------|
| 20 | FIGURE FE818 SINGLE OUTLET | 2 | 57°C | 27°C | Orange | MJCSO0027A |
| | | | 68°C | 38°C | Red | MJCSO0027B |
| | | | 79°C | 49°C | Yellow | MJCSO0027D |
| | | | 93°C | 63°C | Green | MJCSO0027E |
| | | | 141°C | 111°C | Blue | MJCSO0027G |
| 20 | FIGURE FE186 DOUBLE OUTLET | 1 | 57°C | 27°C | Orange | MJCDO0027A |
| | | | 68°C | 38°C | Red | MJCDO0027B |
| | | | 79°C | 49°C | Yellow | MJCDO0027D |
| | | | 93°C | 63°C | Green | MJCDO0027E |
| | | | 141°C | 111°C | Blue | MJCDO0027G |

NOTES:

1. Approved by the Loss Prevention Certification Board (LPCB Refer to No. 007f/01).
2. Approved by the Loss Prevention Certification Board (LPCB Refer to No. 007f/02).

TABLE A
LABORATORY LISTINGS AND APPROVALS
FOR DN20 SERIES MJC MULTIPLE JET CONTROLS

| DN | FIGURE NUMBER and STYLE | APPROVALS | TEMPERATURE RATING | MAXIMUM TEMPERATURE WHERE MJC IS LOCATED | BULB LIQUID COLOR | PART NUMBER DOUBLE OUTLET | PART NUMBER SINGLE OUTLET |
|----|--|-----------|--------------------|--|-------------------|---------------------------|---------------------------|
| 25 | FIGURE FE190 DOUBLE OUTLET WITH GUARD | N/A | 57°C | 27°C | Orange | MJCDO0034A | MJCSO0034A |
| | | 1 | 68°C | 38°C | Red | MJCDO0034B | MJCSO0034B |
| | | N/A | 79°C | 49°C | Yellow | MJCDO0034D | MJCSO0034D |
| | | | 93°C | 63°C | Green | MJCDO0034E | MJCSO0034E |
| | | | 141°C | 111°C | Blue | MJCDO0034G | MJCSO0034G |
| 25 | FIGURE FE2656 DOUBLE OUTLET WITH GUARD AND ELECTRICAL ACTUATOR** | N/A | 57°C | 27°C | Orange | 25013 | * - - - |
| | | | 68°C | 38°C | Red | 25015 | * - - - |
| | | | 79°C | 49°C | Yellow | 25017 | * - - - |
| | | | 93°C | 63°C | Green | 25019 | * - - - |

NOTES:

1. Approved by the Loss Prevention Certification Board (LPCB Refer to No. 007f/03).
- N/A: Not Approved
* Not Available
** On request, available with Walkbery flex cable.

TABLE B
LABORATORY APPROVALS AND PART NUMBERS
FOR DN25 SERIES MJC MULTIPLE JET CONTROLS

| DN | FIGURE NUMBER and STYLE | APPROVALS | TEMPERATURE RATING | MAXIMUM TEMPERATURE WHERE MJC IS LOCATED | BULB LIQUID COLOR | PART NUMBER DOUBLE OUTLET | PART NUMBER SINGLE OUTLET |
|----|--|-----------|--------------------|--|-------------------|---------------------------|---------------------------|
| 40 | FIGURE FE181 DOUBLE OUTLET WITH GUARD | N/A | 57°C | 27°C | Orange | MJCDO0048A | MJCDO0048A |
| | | 1 | 68°C | 38°C | Red | MJCDO0048B | MJCDO0048B |
| | | N/A | 79°C | 49°C | Yellow | MJCDO0048D | MJCDO0048D |
| | | | 93°C | 63°C | Green | MJCDO0048E | MJCDO0048E |
| | | | 141°C | 111°C | Blue | MJCDO0048G | MJCDO0048G |
| 40 | FIGURE FE2378 DOUBLE OUTLET WITH GUARD AND ELECTRICAL ACTUATOR** | N/A | 57°C | 27°C | Orange | 25025 | * - - - |
| | | | 68°C | 38°C | Red | 25027 | * - - - |
| | | | 79°C | 49°C | Yellow | 25029 | * - - - |
| | | | 93°C | 63°C | Green | 25031 | * - - - |

NOTES:
 1. Approved by the Loss Prevention Certification Board (LPCB Refer to No. 007f/03).
 N/A: Not Approved
 * Not Available
 ** On request, available with Walkbery flex cable.

TABLE C
LABORATORY APPROVALS AND PART NUMBERS
FOR DN40 SERIES MJC MULTIPLE JET CONTROLS

| DN | FIGURE NUMBER and STYLE | APPROVALS | TEMPERATURE RATING | MAXIMUM TEMPERATURE WHERE MJC IS LOCATED | BULB LIQUID COLOR | PART NUMBER DOUBLE OUTLET | PART NUMBER SINGLE OUTLET |
|----|--|-----------|--------------------|--|-------------------|---------------------------|---------------------------|
| 50 | FIGURE FE192 DOUBLE OUTLET WITH GUARD | N/A | 57°C | 27°C | Orange | MJCDO0060A | MJCDO0060A |
| | | 1 | 68°C | 38°C | Red | MJCDO0060B | MJCDO0060B |
| | | N/A | 79°C | 49°C | Yellow | MJCDO0060D | MJCDO0060D |
| | | | 93°C | 63°C | Green | MJCDO0060E | MJCDO0060E |
| | | | 141°C | 111°C | Blue | MJCDO0060G | MJCDO0060G |
| 50 | FIGURE FE2073 DOUBLE OUTLET WITH GUARD AND ELECTRICAL ACTUATOR** | N/A | 57°C | 27°C | Orange | 25037 | * - - - |
| | | | 68°C | 38°C | Red | 25039 | * - - - |
| | | | 79°C | 49°C | Yellow | 25041 | * - - - |
| | | | 93°C | 63°C | Green | 25043 | * - - - |

NOTES:
 1. Approved by the Loss Prevention Certification Board (LPCB Refer to No. 007f/03).
 N/A: Not Approved
 * Not Available
 ** On request, available with Walkbery flex cable.

TABLE D
LABORATORY APPROVALS AND PART NUMBERS
FOR DN50 SERIES MJC MULTIPLE JET CONTROLS