



## UNIVERSAL CABINET Pre-assembled Deluge System /



### Star Universal Cabinet

Single Interlock Preaction Systems • Double Interlock Preaction Systems • Deluge Systems

- *Aesthetically Pleasing Appearance*
- *Professionally Pre-Assembled and Pre-Tested*
- *Minimal Installation Time*
- *Internally Pre-wired*
- *UL/ULC/FM Components*
- *Custom Manufactured*
- *Sizes 3, 4 and 6 inch*
- *Straight-Through Flow Pattern*
  - *Reduced Friction Loss*
  - *Valve can be serviced without taking out of line*

A new pre-assembled valve package is now available from Star Sprinkler Inc. Enclosed within a free-standing cabinet, the package consists of the system manual shut-off valve, automatic preaction or deluge valve, release control panel, valve trim, and all electrical switches. The entire package is pre-assembled and pre-wired, and the water inlet and outlet to the riser assembly is grooved to provide minimal installation time. Where air supervision of piping is required, a compressor and controls are also included.

The unit is designed to occupy minimal floor space and provides an aesthetically pleasing enclosure for the assembly. The pre-trim and wiring, installed per the manufacturer's specifications, eliminates hours of labor normally required for installation. The automatic control valves used are the 3, 4, or 6 inch Star Model A Preaction Valve or the 3, 4, or 6 inch Star Model G Deluge Valve, as applicable. The system manual shut-off valve provided with the Universal Cabinet is a gear operated butterfly valve with tamper switch. All of the sprinkler riser components are UL/ULC Listed, and/or FM Approved.

The standard releasing panel for the Star Universal Cabinet is manufactured by Potter Electric. The Potter Electric Model PFC-4410 provides for single zone or cross-zoned detection systems and releasing of the automatic control valve. Other releasing panels are available upon request, and the control functions can be specified at the time of order. All switches within the cabinet are pre-wired to the releasing panel, making the connections for power (115 VAC), detection circuits, associated equipment shutdowns, and local and remote alarms to the panel the only remaining connections to complete the electrical functions of the system. Compressors over 1/2 hp are available in 115V or 230V. Internal electrical junction boxes meet the requirements of NEMA 12, and per NFPA requirements, provision is made to connect a separate power line when a system air compressor is provided in the Star Universal Cabinet.

The water inlet and outlet sizes are the same as the ordered preaction or deluge valve size. The standard inlet and outlet are grooved, and the connections are within the cabinet. The main drain is pre-piped to a drain line, which terminates within the cabinet, and is also grooved. For ease of installation, the outlet installation to the system is in the vertical position, and the grooved connection to the inlet and the main drain connections are in the horizontal position. The valve trim assemblies are modular for easy access and removal.

The cabinet is constructed of 14 gauge steel, and is free standing. The standard paint finish is bright red. The front door of the enclosure is fully hinged for easy access, and windows have been provided for viewing the releasing panel functions and essential system pressure gauges. A lock for the cabinet door is optional.

*Note:* Star Sprinkler Inc. does not represent these guidelines as a complete system, since they cover only the valve riser components. It is the intent of these sample specifications to provide a guideline only in writing a fire system specification utilizing a pre-assembled riser assembly. The user must be aware that choices must be made on sound engineering practices. It is the responsibility of the specifying engineer to specify an adequate and complete system for the building owner. It is the intent of these sample specifications to only guide him in that task.

## STAR UNIVERSAL CABINET “DELUGE SYSTEMS”

### 1. SYSTEM DESCRIPTION AND COMPONENTS

---

a) Provide, deliver, and install a fully integrated and assembled, Star Universal Cabinet deluge system for the protection of the following areas:

1) NOTE: ARCHITECT or ENGINEER to provide a detailed list of rooms or areas protected.

b) Each deluge system shall have the main following components that are to be part of the system known as the Star Universal Cabinet as manufactured by Star Sprinkler Company:

1) Sturdy steel cabinet, 14 gauge, nominal 60” high (66” high for 6” system) x 36” wide x 24” deep. Cabinet shall be scratch resistant fire-red powder paint inside and out.

2) Internally mounted NEMA 12 junction boxes for easy connection of power and devices. A separate junction box shall be provided for power connections.

3) Hydraulic manual release unit with tamper resistant cover shall be located inside of the Star Universal Cabinet.

4) Star Model G (3, 4, or 6”) deluge valve with electric actuation, drain, and alarm trim all pre-piped and factory tested, as shown in Star Product Data Sheet 2-3.1.10(3”), 2-3.1.20(4”), or 2-3.1.30 (6”). Sizing of valves to be determined by hydraulic calculations by the CONTRACTOR.

5) Potter Model PFC-44IO releasing panel, UL listed and FM approved, with separate locked door. The releasing panel shall be mounted in a neat workmanlike manner in the Star Universal Cabinet door and have a minimum of two 7Ah, 12V batteries as manufactured by Potter. Releasing panel shall have alphanumeric display and 40 event history feature.

6) Gear operated butterfly valve with tamper switch shall be provided for manual system shut-off valve.

7) Cabinet shall include an electric alarm switch for notification of valve actuation. It shall also include a low pressure alarm switch for monitoring system piping integrity.

c) All internal piping for the Star Universal Cabinet shall be pre-piped, factory mounted and tested as follows:

1) Header shall be schedule 40, steel pipe, grooved ends. Piping shall be sized the same as the deluge valve.

2) Main Drain Header shall be schedule 40, 2” steel pipe, grooved ends.

3) Funnel Drain Header shall be 1”, schedule 40, steel pipe, thread.

d) All components shall be mounted on unions to allow ease of maintenance or repair. No hoses shall be used.

e) All fire protection riser components shall be UL, ULC, and/or FM approved for use in fire protection.

### 2. SYSTEM OPERATION

---

a) Normal Operation

1) During normal operation there is no water in the sprinkler piping downstream from the Star Universal Cabinet unit. This piping contains only atmospheric air. The Star Universal Cabinet releasing panel displays a banner message on the liquid crystal display (LCD) indicating that the power is on and no trouble or alarm condition exists. The releasing panel monitors the electrical lines of all electrical devices connected to it for ground fault, short circuit or open circuit conditions.

b) Closing of Manual System Shut-Off Valve

1) The closing of the manual system shut-off valve located in the Star Universal Cabinet will cause a local buzzer to sound, the message “GATE VALVE” will be displayed on the panel LCD, and the supervision contact will be actuated. The local signal can be silenced by pressing the LOCAL SILENCE button accessed by opening the locked panel door.

2) Upon silencing, a gate valve acknowledge will be recorded in the panel's event history, and “GATE VALVE” message will be displayed until the condition has been removed.

c) Discharge

1) If a fire condition occurs, the control panel will record the event and sequence of operation. The detection circuit will normally indicate a fire condition and send a signal to the releasing panel. Upon a signal from the releasing panel to the valve, the valve will open and water will discharge from all sprinkler heads.

2) The panel will actuate a non silenceable water flow alarm circuit upon opening of the valve and filling the sprinkler lines with water. This condition can only be silenced by removing the water flow condition and resetting the releasing panel. A set of form “C” contacts suitable for equipment shut-down control signals is actuated upon opening of the valve and filling the sprinkler lines with water.

d) Trouble Conditions

Indicating appliance / releasing circuits:

Short circuit or open circuit conditions will result in the following:

a) "TROUBLE" and "OUTPUT#" (circuit no.) will be displayed on the LCD.

b) Activation of trouble relay contacts, trouble LED and local buzzer.

Ground Fault:

A ground fault will result in the following:

a) "TROUBLE" and "GROUND" displayed on the LCD.

b) Activation of trouble relay contacts, trouble LED and local buzzer.

Low Battery Voltage:

Loss or reduction of battery voltage to 22 volts will result in the following:

a) "TROUBLE" and "BATTERY" will be displayed on the LCD.

b) Activation of trouble relay contacts, trouble LED and local buzzer.

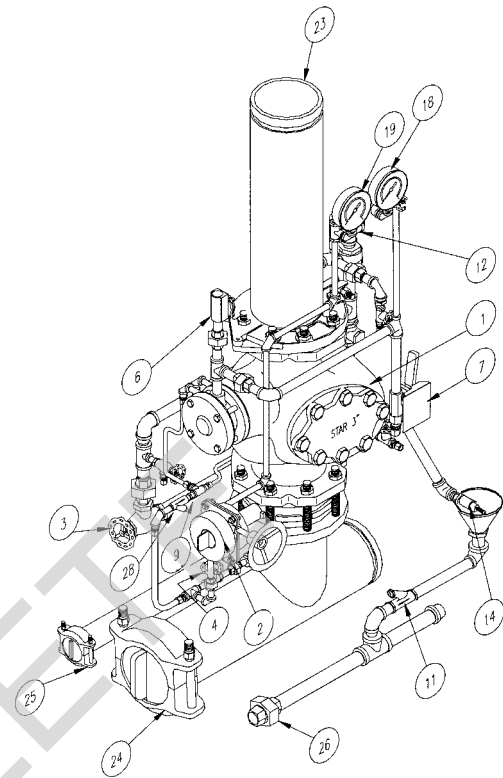

DELUGE CABINET TABLE

PART NAME	PRODUCT DATA SHEET		
	3"	4"	6"
1 Deluge Valve	2-3.1.10	2-3.1.20	2-3.1.30
2 Supervised Control Valve	UL/ULC/FM Listed Butterfly Valve	UL/ULC/FM Listed Butterfly Valve	UL/ULC/FM Listed Butterfly Valve
3 Main Drain Valve	2-3.1.10	2-3.1.20	2-3.1.30
4 Differential Chamber Supply Valve	2-3.1.10	2-3.1.20	2-3.1.30
5 Alarm Control Valve (not shown)	2-3.1.10	2-3.1.20	2-3.1.30
6 Solenoid Valve	2-3.1.10	2-3.1.20	2-3.1.30
7 Manual Control Station	2-3.1.10	2-3.1.20	2-3.1.30
8 Alarm Test Valve (not shown)	2-3.1.10	2-3.1.20	2-3.1.30
9 Check Valve	2-3.1.10	2-3.1.20	2-3.1.30
10 N/A			
11 Funnel Drain Check Valve	2-3.1.10	2-3.1.20	2-3.1.30
12 Side Outlet Gauge Valve	2-3.1.10	2-3.1.20	2-3.1.30
13 N/A			
14 Automatic Drain Valve	2-3.1.10	2-3.1.20	2-3.1.30
15 Check Valve (not shown)	2-3.1.10	2-3.1.20	2-3.1.30
16 N/A			
17 N/A			
18 Differential Chamber Pressure Gauge	2-3.1.10	2-3.1.20	2-3.1.30
19 Water Supply Pressure Gauge	2-3.1.10	2-3.1.20	2-3.1.30
20 N/A			
21 Waterflow Pressure Alarm Switch (not shown)	Potter PS10	Potter PS10	Potter PS10
22 N/A			
23 Grooved System Connection Schedule 40	Schedule 40 Black Steel	Schedule 40 Black Steel	Schedule 40 Black Steel
24 Grooved Supply Connection Schedule 40	Schedule 40 Black Steel	Schedule 40 Black Steel	Schedule 40 Black Steel
25 Grooved Main Drain Connection 2" Schedule 40	Schedule 40 Black Steel	Schedule 40 Black Steel	Schedule 40 Black Steel
26 Threaded Funnel Drain Connection 1" NPT Schedule 40	Schedule 40 Black Steel	Schedule 40 Black Steel	Schedule 40 Black Steel
27 Water Motor Gong Connection (not shown)	2-3.1.10	2-3.1.20	2-3.1.30
28 Strainer	2-3.1.10	2-3.1.20	2-3.1.30
29 Control Panel (not shown)	Potter PFC-4410	Potter PFC-4410	Potter PFC-4410

\* Refer to General Air data sheet

**CABINET DIMENSIONS – 3”, 4” AND 6” ALL CONFIGURATIONS**

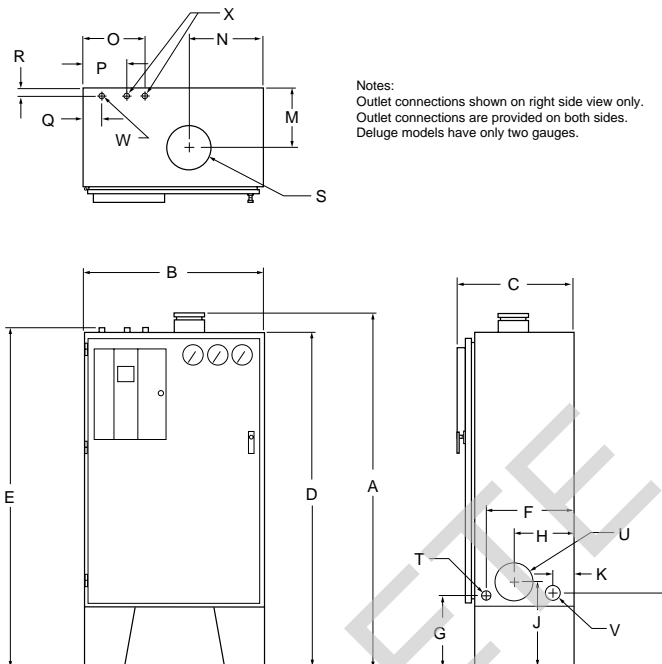

Notes:  
 Outlet connections shown on right side view only.  
 Outlet connections are provided on both sides.  
 Deluge models have only two gauges.

**DIMENSION TABLE**

3”, 4” and 6” Cabinet Dimensions – All Configurations

Label	Description	Nominal Dimensions					
		3”		4”		6”	
		inch	mm	inch	mm	inch	mm
A	Overall Height	63-1/4	1607	63	1600	69-1/2	1765
B	Overall Width	36	914	36	914	36	914
C	Overall Depth	23-1/2	597	23-1/2	597	23-1/2	597
D	Cabinet Height	60	1524	60	1524	66	1676
E	Electrical Conduit Height	61-1/2	1562	61-1/2	1562	67-1/2	1715
F	Funnel Drain Location from Back (centerline)	18	457	18	457	18-1/2	470
G	Funnel Drain Connection Height (centerline)	14-1/4	362	14-1/4	362	14-1/4	362
H	Water Supply Connection from Back (centerline)	11-3/4	298	11-3/4	298	12-1/4	311
J	Water Supply Connection Height (centerline)	15-1/2	394	16	406	17	432
K	Main Drain Connection from Back (centerline)	4-1/4	108	4-1/4	108	4-1/4	108
L	Main Drain Connection Height (centerline)	14-3/4	375	14-3/4	375	14-3/4	375
M	System Connection from Back (centerline)	11-3/4	298	11-3/4	298	12-1/4	311
N	System Connection from Side (centerline)	15	381	15	381	13-1/2	343
O	Large Junction Box Entry Two from Side	12-1/4	311	12-1/4	311	12-1/4	311
P	Large Junction Box Entry One from Side	8-1/2	216	8-1/2	216	8-1/2	216
Q	Small Junction Box Entry from Side	3-1/2	89	3-1/2	89	3-1/2	89
R	Junction Box Entries from Back	1-1/2	38	1-1/2	38	1-1/2	38
S	System Connection – Grooved Schedule 40	3”		4”		6”	
T	Funnel Drain Heater – 1” NPT Schedule 40						
U	Water Supply Entry – Grooved Schedule 40	3”		4”		6”	
V	Main Drain Header – Grooved 2” Schedule 40						
W	Electrical Power Entry – electrical conduit						
X	Electrical Signal Entry – electrical conduit						
Y	Weight	550 lbs / 250 kg		625 lbs / 284 kg		820 lbs / 372 kg	

