

Model A

2.8, 4.2, 5.6 & 8.0 K-factor

Standard Response

Standard Coverage

Upright & Pendent Pendent Fusible Solder Type Automatic Sprinkler

Tyco Fire Products --- www.centraisprinkler.com
 451 North Cannon Avenue, Lansdale, Pennsylvania 19446 --- USA
 Customer Service/Sales: Tel: (215) 362-0700 / Fax: (215) 362-5385
 Technical Services: Tel: (800) 381-9312 / Fax: (800) 791-5500



General Description

The Central Model A Upright & Pendent Automatic Sprinklers are standard response - standard coverage, fusible solder type spray sprinklers designed for use in light, ordinary, or extra hazard, commercial occupancies such as banks, hotels, shopping malls, factories, refineries, chemical plants, etc.

These sprinklers are available with wax and lead coatings that may be utilized to extend the life of copper alloy sprinklers beyond that which would otherwise be obtained when exposed to corrosive atmospheres.

Although wax and lead coated sprinklers have passed the standard corrosion tests of the applicable approval agencies, the testing is not representative of all possible corrosive atmospheres. Consequently, it is recommended that the end user be consulted with respect to the suitability of these corrosion resistant coatings for any given corrosive environment. The effects of ambient temperature, concentration of chemicals, and gas/chemical velocity, should be considered, as a minimum, along with the corrosive nature of the chemical to which the sprinklers will be exposed.

Operation: A fusible alloy is sealed into a bronze actuating rod (center strut) by a stainless steel ball. When the alloy melts at its rated temperature, the ball is forced upward into the center strut, releasing the two ejectors and operating the sprinkler.

WARNING

The Model A Upright & Pendent Sprinklers described herein must be installed and maintained in compliance with this document, as well as with the applicable standards of the National Fire Protection Association, in addition to the standards of any other authorities having jurisdiction. Failure to do so may impair the integrity of these devices.

The owner is responsible for maintaining their fire protection system and devices in proper operating condition. The installing

contractor or sprinkler manufacturer should be contacted relative to any questions.



Technical Data

Sprinkler Identification Number

SIN C1211 - A Pend (K=2.8)
 SIN C1111 - A UP (K=2.8)
 SIN C2211 - A Pend (K=4.2)
 SIN C2111 - A UP (K=4.2)
 SIN C3211 - A Pend (K=5.6)*
 SIN C3111 - A UP (K=5.6)*
 SIN C4211 - A Pend (K=8.0)*
 SIN C4111 - A UP (K=8.0)*
 SIN C4911 - A Pend (K=8.0, 1/2" NPT)*
 SIN C4811 - A UP (K=8.0, 1/2" NPT)*

Approvals

UL & ULC Listed. FM, LPC, VDS, NYC Approved
 (Refer to Table 1 - 4. The approvals apply only to the service conditions indicated in the Design Criteria Section)

Maximum Working Pressure

175 psi (12,1 bar)
 250 psi (17,3 bar) UL & ULC (K=5.6)

Pipe Thread Connection

1/2 inch NPT -(K=2.7, 4.2, 5.6 & 8.0)
 3/4 inch NPT - (K=8.0)

Discharge Coefficient

K = 2.8 GPM/psi^{1/2} (40,3 LPM/bar^{1/2})
 K = 4.2 GPM/psi^{1/2} (60,5 LPM/bar^{1/2})
 K = 5.6 GPM/psi^{1/2} (80,6 LPM/bar^{1/2})
 K = 8.0 GPM/psi^{1/2} (116,8 LPM/bar^{1/2})

Temperature Ratings

165°F/74°C, 212°F/100°C, 286°F/141°C

Finishes

Sprinkler: White Polyester, Chrome Plated, or Natural Brass

Corrosion Resistant Coatings

Sprinkler: Wax, Lead & Wax-over-Lead

* Head Guard & Water Shield:

G-2 (Guard) - (K=5.6 & K=8.0) Up & Pend.
 WSG-2 (Guard & Shield) - (K=8.0) Up
 WS-2 (Shield) - (K=5.6) Pendent
 Factory Assembled Model A Pendent and Model A ML Shield - (K=5.6 & K=8.0)

(See Data Sheet 3-12.0 for details)



Standard Spray Upright & Pendent Sprinklers

Physical Characteristics

The Model A Upright & Pendent Sprinklers utilize a dezincification resistant (DZR) bronze frame and a brass deflector. The waterway is sealed with copper seal disk, and the fusible assembly is constructed of bronze and stainless steel components.

Figure 1 - Model A, Upright Sprinkler

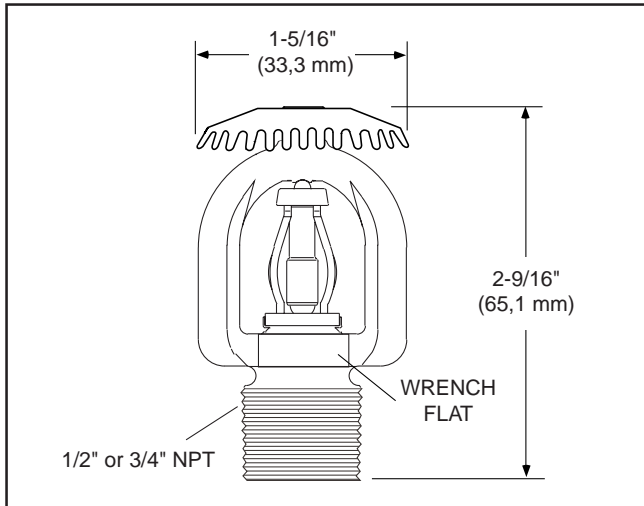

Figure 2 - Model A, Pendent Sprinkler

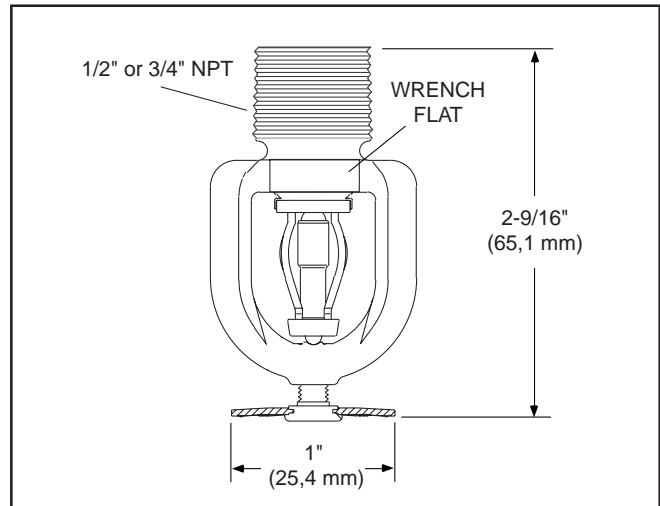

Figure 3 - Cross Section Model A, Upright Sprinkler

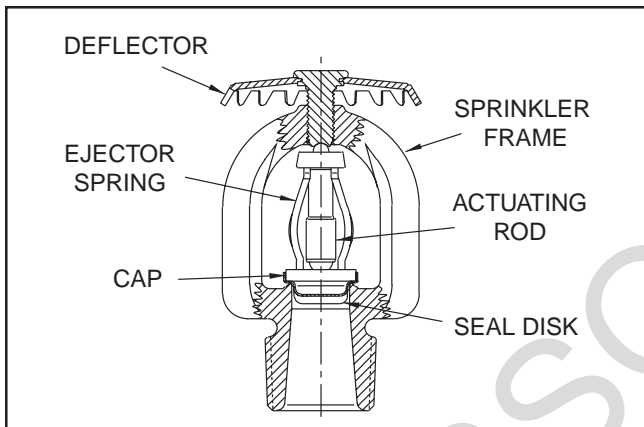

Figure 4 - Combination Sprinkler Wrench (Part #1106)



Design Criteria

The Model A Upright & Pendent Sprinklers are Standard Response, Standard Coverage, Spray Sprinklers intended for fire protection systems designed in accordance with the standard installation rules recognized by the applicable Listing or Approval agency.

The 2.8, 4.2, 5.6 & 8.0 K-Factor, Model A Sprinklers (Ref. Table 1-4) are UL, ULC Listed and NYC Approved for use in accordance with current NFPA standards.

The 2.8, 5.6 & 8.0 K-Factor, Model A Sprinklers (Ref. Table 1-4) are FM Approved for use in accordance with the FM Loss Prevention Data Sheets.

The Model A Sprinklers can be used with any metallic flush or extended escutcheon, provided the maximum ceiling to top of sprinkler deflector dimension specified in NFPA 13 is maintained. For recessed applications, see Data Sheet 1-2.0

(K=2.8,4.2 & 8.0) & 1-3.0 (K=5.6) for details.

NOTE

Inquiries concerning the appropriateness of wax or lead coated sprinklers for a given corrosive environment should be submitted to the attention of the Technical Services Department. Wax or lead coated sprinklers are not suitable for use in open sprinkler applications.

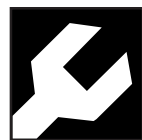

Installation

The Model A Upright & Pendent Sprinklers must be installed in accordance with the following instructions.

NOTES

A leak tight 1/2 inch NPT sprinkler joint should be obtained with a torque of 7 to 14 ft.lbs. (9,5 to 19,0 Nm). A maximum of 21 ft.lbs. (28,5 Nm) of torque is to be used to install 1/2 inch NPT sprinklers.

A leak tight 3/4 inch NPT sprinkler joint should be obtained with a torque of 10 to 20 ft.lbs. (13,4 to 26,8 Nm). A maximum of 30 ft.lbs. (40,7 Nm) of torque is to be used to install 3/4 inch NPT sprinklers. Higher levels of torque may distort the sprinkler inlet with consequent leakage or impairment of the sprinkler.

Step 1. Upright sprinklers must be installed only in the upright position and pendent sprinklers must be installed only in the pendent position. The deflector is to be parallel to the ceiling, roof, or mounting surface, as applicable.

Step 2. With pipe thread sealant applied to the pipe threads, hand tighten the sprinkler into the sprinkler fitting.

Step 3. Tighten the sprinkler into the sprinkler fitting using only the Combination Wrench (Ref. Figure 4), except that an 8 or 10 inch adjustable Crescent wrench is to be used for wax coated

(Continued on page 4)

Table 1 - Laboratory Listings and Approvals (2.8 K-factor Sprinklers)

| | | SPRINKLER FINISH | | | | | |
|--------------------|------------------|---------------------|---------------|------------------|-------------|------------|----------------------|
| | | Pendent and Upright | | | | | |
| Temperature Rating | Frame Color Code | Natural Brass | Chrome Plated | Polyester Coated | Lead Coated | Wax Coated | Wax Over Lead Coated |
| 165°F/74°C | Unpainted | 1,3,4*,8 | 1,3,4*,8 | 1,8 | 1,3,4* | 1,3 | 1 |
| 212°F/100°C | White | 1,3,4*,8 | 1,3,4*,8 | 1,8 | 1,3,4* | 1,3,4* | 1 |
| 286°F/141°C | Blue | 1,3,8 | 1,3,8 | 1,8 | 1 | 2 | 2 |

Table 2 - Laboratory Listings and Approvals (4.2 K-factor Sprinklers)

| | | SPRINKLER FINISH | | | | | |
|--------------------|------------------|---------------------|---------------|------------------|-------------|------------|----------------------|
| | | Pendent and Upright | | | | | |
| Temperature Rating | Frame Color Code | Natural Brass | Chrome Plated | Polyester Coated | Lead Coated | Wax Coated | Wax Over Lead Coated |
| 165°F/74°C | Unpainted | 1,3,8 | 1,3,8 | 1,8 | 1,3 | 1,3 | 1 |
| 212°F/100°C | White | 1,3,8 | 1,3,8 | 1,8 | 1,3 | 1,3 | 1 |
| 286°F/141°C | Blue | 1,3,8 | 1,3,8 | 1,8 | 1 | 2 | 2 |

Table 3 - Laboratory Listings and Approvals (5.6 K-factor Sprinklers)

| | | SPRINKLER FINISH | | | | | |
|--------------------|------------------|---------------------|---------------|------------------|-------------|------------|----------------------|
| | | Pendent and Upright | | | | | |
| Temperature Rating | Frame Color Code | Natural Brass | Chrome Plated | Polyester Coated | Lead Coated | Wax Coated | Wax Over Lead Coated |
| 165°F/74°C | Unpainted | 1,3,4,6,7,8 | 1,3,4,6,8 | 1,8 | 1,3,4 | 1,3,4 | 1,4 |
| 212°F/100°C | White | 1,3,4,6,7,8 | 1,3,4,6,8 | 1,8 | 1,3,4 | 1,3,4 | 1,4 |
| 286°F/141°C | Blue | 1,3,4,6,7,8 | 1,3,4,6,8 | 1,8 | 1,4 | 2,5 | 2 |

Table 4 - Laboratory Listings and Approvals (8.0 K-factor Sprinklers with 1/2" or 3/4" NPT)

| | | SPRINKLER FINISH | | | | | |
|--------------------|------------------|---------------------|---------------|------------------|-------------|------------|----------------------|
| | | Pendent and Upright | | | | | |
| Temperature Rating | Frame Color Code | Natural Brass | Chrome Plated | Polyester Coated | Lead Coated | Wax Coated | Wax Over Lead Coated |
| 165°F/74°C | Unpainted | 1,3,4,6**,7**,8 | 1,3,4,8 | 1,8 | 1,3,4 | 1,3 | 1 |
| 212°F/100°C | White | 1,3,4,6**,7**,8 | 1,3,4,8 | 1,8 | 1,3,4 | 1,3 | 1 |
| 286°F/141°C | Blue | 1,3,4,6**,7**,8 | 1,3,4,8 | 1,8 | 1,4 | 2,5 | 2 |

Notes:

1. Listed by Underwriters Laboratories, Inc.
2. Listed by Underwriters Laboratories, Inc. for maximum 150°F/68°C ambient temperatures.
3. Listed by Underwriters' Laboratories of Canada.
4. Approved by Factory Mutual Research Corporation.
5. Approved by Factory Mutual Research Corporation for maximum 150°F/68°C ambient temperatures.

6. Approved by the Loss Prevention Council (United Kingdom).
7. Approved by Verband der Schadeversicherer
8. Approved by the City of New York under BSA 375-75-SA

*Upright Only
 **Not approved with 1/2" NPT



Installation (Continued)

sprinklers. With reference to Figure 1 & 2, both the Combination Wrench and the adjustable Crescent wrench are to be applied to the wrench flats only.

When installing wax coated sprinklers with the adjustable Crescent wrench, additional care needs to be exercised to prevent damage to the wax coating on the sprinkler wrench flats or frame arms and, consequently, exposure of bare metal to the corrosive environment. The jaws of the wrench should be opened sufficiently wide to pass over the wrench flats without damaging the wax coating. Before wrench tightening the sprinkler, the jaws of the wrench are to be adjusted to just contact the sprinkler wrench flats. After wrench tightening the sprinkler, loosen the wrench jaws before removing the wrench.

After installation, the sprinkler wrench flats and frame arms must be inspected and the wax coating retouched (repaired) whenever the coating has been damaged and bare metal is exposed. The wax coating on the wrench flats can be retouched by gently applying a heated 1/8 inch diameter steel rod to the areas of wax that have been damaged, to smooth it back over areas where bare metal is exposed.

NOTES

Only retouching of the wax coating applied to the wrench flats and frame arms is permitted, and the retouching is to be performed only at the time of the initial sprinkler installation.

The steel rod should be heated only to the point at which it can begin to melt the wax, and appropriate precautions need to be taken, when handling the heated rod, in order to prevent the installer from being burned.

If attempts to retouch the wax coating with complete coverage are unsuccessful, additional wax can be ordered in the form of a wax block. Care should be exercised to assure that the proper rated temperature wax block is ordered. Only the correct temperature wax is to be used, and retouching of wrench flats and frame arms is only permitted at the time of initial sprinkler installation. With the steel rod heated as previously described, touch the rod to the area requiring additional wax with the rod angled downward, and then touch a portion of the wax block to the rod approximately one-half inch away from the area requiring retouching. The wax will melt and run down onto the sprinkler.



Care & Maintenance

The Model A Upright & Pendent Sprinklers must be maintained and serviced in accordance with the following instructions.

NOTES

Absence of an escutcheon which is used to cover a clearance hole, may delay the time to operation in a fire situation.

Before closing a fire protection system main control valve for maintenance work on the fire protection system it controls, permission to shut down the affected fire protection systems must be obtained from the proper authorities. All personnel who may be affected by this action must be notified.

Sprinklers which are found to be leaking or exhibiting visible signs of corrosion must be replaced.

Automatic sprinklers must never be shipped or stored where their temperatures will exceed 100°F/38°C and they must never be painted, plated, coated or otherwise altered after leaving the factory. Modified sprinklers must be replaced. Sprinklers that have been exposed to corrosive products of combustion, but have not operated, should be replaced if they cannot be completely cleaned by wiping the sprinkler with a cloth or by brushing it with a soft bristle brush.

Care must be exercised to avoid damage - before, during, and after installation. Sprinklers damaged by dropping, striking, wrench twist/slippage, or the like, must be replaced.

Frequent visual inspections are recommended to be initially performed for wax and/or lead coated sprinklers, after the installation has been completed, to verify the integrity of the wax and/or lead coating. Thereafter, annual inspections per NFPA 25 should suffice; however, instead of inspecting from the floor level, a random sampling of close-up visual inspections should be made, so as to better determine the exact sprinkler condition and the long term integrity of the wax and/or lead coating, as it may be affected by the corrosive conditions present.

The owner is responsible for the inspection, testing, and maintenance of their fire protection system and devices in compliance with this document, as well as with the applicable standards of the National Fire Protection Association (e.g., NFPA 25), in addition to the standards of any other authorities having jurisdiction. The installing contractor or sprinkler manufacturer should be contacted relative to any questions.

It is recommended that automatic sprinkler systems be inspected, tested, and maintained by a qualified Inspection Service.



Limited Warranty

Products manufactured by Tyco Fire Products are warranted solely to the original Buyer for ten (10) years against defects in material and workmanship when paid for and properly installed and maintained under normal use and service. This warranty will expire ten (10) years from date of shipment by Tyco Fire Products. No warranty is given for products or components manufactured by companies not affiliated by ownership with Tyco Fire Products or for products and components which have been subject to misuse, improper installation, corrosion, or which have not been installed, maintained, modified or repaired in accordance with applicable Standards of the National Fire Protection Association, and/or the standards of any other Authorities Having Jurisdiction. Materials found by Tyco Fire Products to be defective shall be either repaired or replaced, at Tyco Fire Products' sole option. Tyco Fire Products neither assumes, nor authorizes any person to assume for it, any other obligation in connection with the sale of products or parts of products. Tyco Fire Products shall not be responsible for sprinkler system design errors or inaccurate or incomplete information supplied by Buyer or Buyer's representatives.

IN NO EVENT SHALL TYCO FIRE PRODUCTS BE LIABLE, IN CONTRACT, TORT, STRICT LIABILITY OR UNDER ANY OTHER LEGAL THEORY, FOR INCIDENTAL, INDIRECT, SPECIAL OR CONSEQUENTIAL DAMAGES, INCLUDING BUT NOT LIMITED TO LABOR CHARGES, REGARDLESS OF WHETHER TYCO FIRE PRODUCTS WAS INFORMED ABOUT THE POSSIBILITY OF SUCH DAMAGES, AND IN NO EVENT SHALL TYCO FIRE PRODUCTS' LIABILITY EXCEED AN AMOUNT EQUAL TO THE SALES PRICE.

THE FOREGOING WARRANTY IS MADE IN LIEU OF ANY AND ALL OTHER WARRANTIES EXPRESS OR IMPLIED, INCLUDING WARRANTIES OF MERCHANTABILITY AND FITNESS FOR A PARTICULAR PURPOSE.



Ordering Information

Ordering Information: When placing an order, indicate the full product name. Please specify the quantity, model, style, orifice size, temperature rating, type of finish or coating, and sprinkler wrench. Refer to price list for complete listing of Part Numbers.

Teflon is a trademark of the DuPont Corp.