

RAPID RESPONSE Series LFII Residential Sprinklers 5.8 K-factor Pendent and Recessed Pendent Wet Pipe Systems

General Description

The TYCO RAPID RESPONSE Series LFII Residential Pendent and Recessed Pendent Sprinklers (TY3934) are decorative, fast response, frangible bulb sprinklers designed for use in residential occupancies such as homes, apartments, dormitories, and hotels. When aesthetics and optimized flow characteristics are the major consideration, the Series LFII Residential Sprinklers (TY3934) should be the first choice.

The Series LFII Residential Sprinklers are intended for use in the following scenarios:

- wet pipe residential sprinkler systems for one- and two-family dwellings and mobile homes per NFPA 13D
- wet pipe residential sprinkler systems for residential occupancies up to and including four stories in height per NFPA 13R
- wet pipe sprinkler systems for the residential portions of any occupancy per NFPA 13

The recessed version of the Series LFII Residential Sprinklers is intended for use in areas with finished ceilings. It employs a two-piece Style 20 Recessed Escutcheon. The Recessed Escutcheon provides 1/4 inch (6,4 mm) of recessed adjustment or up to 1/2 inch (12,7 mm) of total adjustment from the flush ceiling position. The adjustment provided by the Recessed Escutcheon reduces the accuracy to

IMPORTANT

Always refer to Technical Data Sheet TFP700 for the "INSTALLER WARNING" that provides cautions with respect to handling and installation of sprinkler systems and components. Improper handling and installation can permanently damage a sprinkler system or its components and cause the sprinkler to fail to operate in a fire situation or cause it to operate prematurely.

which the pipe drops to the sprinklers must be cut.

The Series LFII Residential Sprinklers have been designed with heat sensitivity and water distribution characteristics proven to help in the control of residential fires and to improve the chance for occupants to escape or be evacuated.

NOTICE

The Series LFII Residential Pendent and Recessed Pendent Sprinklers (TY3934) described herein must be installed and maintained in compliance with this document and the applicable standards of the National Fire Protection Association, in addition to the standards of any authorities having jurisdiction. Failure to do so may impair the performance of these devices.

The owner is responsible for maintaining their fire protection system and devices in proper operating condition. Contact the installing contractor or product manufacturer with any questions.

Sprinkler Identification Number (SIN)

TY3934

Technical Data

Approvals
UL and C-UL Listed

Certified to all requirements of
NSF/ANSI 61

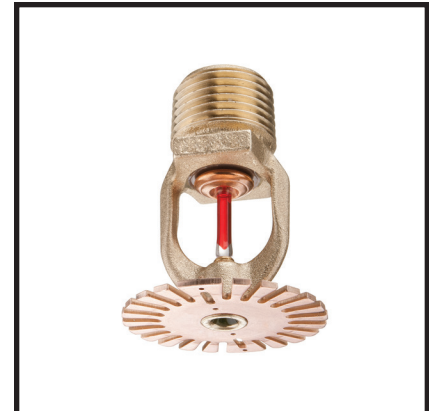

Discharge Coefficient
K = 5.8 gpm/psi^{1/2} (83,5 lpm/bar^{1/2})

Temperature Rating
155°F (68°C) or 175°F (79°C)

Finishes
Natural Brass
Pure or Signal White
Jet Black
Chrome Plated

Physical Characteristics

Frame	Brass
Button	Bronze
Sealing Assembly ..	Beryllium Nickel w/TEFLON
Bulb (3 mm)	Glass
Compression Screw ..	Brass
Deflector	Brass

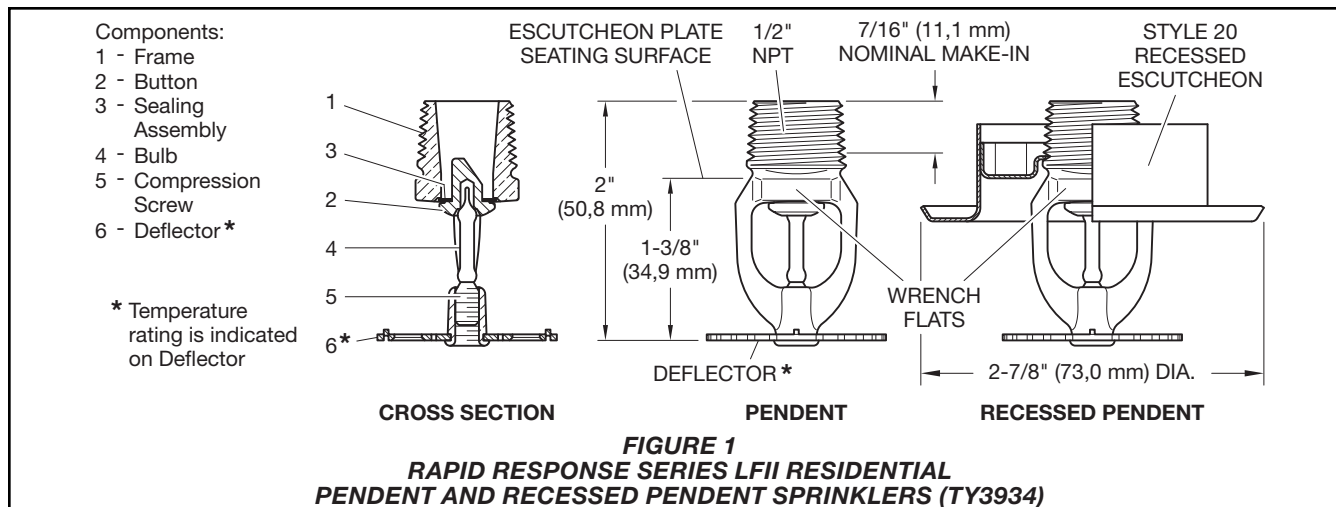

Operation

The glass bulb contains a fluid that expands when exposed to heat. When the rated temperature is reached, the fluid expands sufficiently to shatter the glass bulb, allowing the sprinkler to activate and flow water.

Design Criteria

The TYCO RAPID RESPONSE Series LFII Residential Pendent and Recessed Pendent Sprinklers (TY3934) are to be installed in accordance with this section.

Residential Sprinkler Design Guide

When conditions exist that are outside the scope of the provided criteria, refer to the Residential Sprinkler Design Guide TFP490 for the manufacturer's recommendations that may be acceptable to the local authority having jurisdiction.

Ceiling Types

Smooth flat horizontal, or beamed, or sloped, in accordance with the 2013 Edition of NFPA 13D, 13R, or 13 as applicable.

Hydraulic Design (NFPA 13D and 13R)

For systems designed to NFPA 13D or NFPA 13R, the minimum required sprinkler flow rates are given in Table A as a function of temperature rating and the maximum allowable coverage areas. The sprinkler flow rate is the minimum required discharge from each of the total number of "design sprinklers" as specified in NFPA 13D or NFPA 13R. The number of "design sprinklers" specified in NFPA 13D and 13R for wet pipe systems is to be applied when designing dry pipe systems.

Hydraulic Design (NFPA 13)

For systems designed to NFPA 13, the number of design sprinklers is to be the four most hydraulically demanding sprinklers. The minimum required discharge from each of the four sprinklers is to be the greater of the following:

- The flow rates given in Table A as a function of temperature rating and the maximum allowable coverage area.
- A minimum discharge of 0.1 gpm/ft² over the "design area" comprised of the four most hydraulically demanding sprinklers for actual coverage areas protected by the four sprinklers.

Obstruction to Water Distribution

Sprinklers are to be located in accordance with the obstruction rules of NFPA 13D, 13R, and 13 as applicable for residential sprinklers as well as with the obstruction criteria described within the Technical Data Sheet TFP490.

Operational Sensitivity

Sprinklers are to be installed with a deflector-to-ceiling distance of 1 to 4 inches below smooth ceilings.

For "Beamed Ceiling" conditions as allowed by NFPA, the maximum deflector distance below the bottom of a beam is 1-3/4 inches. See NFPA Standards for allowed beam configurations.

Sprinkler Spacing

The minimum spacing between sprinklers is 8 feet (2,4 m). The maximum spacing between sprinklers cannot exceed the length of the coverage area (Table A) being hydraulically calculated (e.g., maximum 12 feet for a 12 ft. x 12 ft. coverage area, or 20 feet for a 20 ft. x 20 ft. coverage area).

Installation

The TYCO RAPID RESPONSE Series LFII Residential Pendent and Recessed Pendent Sprinklers (TY3934) must be installed in accordance with this section.

General Instructions

Do not install any bulb type sprinkler if the bulb is cracked or there is a loss of liquid from the bulb. With the sprinkler held horizontally, a small air bubble should be present. The diameter of the air bubble is approximately 1/16 inch (1,6 mm).

A leak-tight 1/2 inch NPT sprinkler joint should be obtained by applying a minimum-to-maximum torque of 7 to 14 ft.-lbs. (9,5 to 19,0 Nm). Higher levels of torque can distort the sprinkler Inlet with consequent leakage or impairment of the sprinkler.

Do not attempt to compensate for insufficient adjustment in an Escutcheon Plate by under- or over-tightening the sprinkler. Re-adjust the position of the sprinkler fitting to suit.

Series LFII Residential Pendent Sprinkler Installation

The Series LFII Residential Pendent Sprinklers must be installed in accordance with the following instructions.

Step 1. Install pendent sprinklers in the pendent position with the deflector parallel to the ceiling.

Step 2. With pipe thread sealant applied to the pipe threads, hand-tighten the sprinkler into the sprinkler fitting.

Step 3. Tighten the sprinkler into the sprinkler fitting using only the W-Type 6 Sprinkler Wrench (Figure 3). With reference to Figure 1, apply the W-Type 6 Sprinkler Wrench to the wrench flats.

Max. Coverage Area (a) Ft. x Ft. (m x m)	WET PIPE SYSTEM Minimum Flow and Residual Pressure ^(b, c)				Deflector to Ceiling	Installation Type	Minimum Spacing Ft. (m)
	Ordinary Temp. Rating 155°F (68°C)		Intermediate Temp. Rating 175°F (79°C)				
	Flow gpm (lpm)	Pressure psi (bar)	Flow gpm (lpm)	Pressure psi (bar)			
12 x 12 (3,7 x 3,7)	16 (60,6)	7.6 (0,52)	16 (60,6)	7.6 (0,52)	Smooth Ceilings 1 to 4 inches Beamed Ceilings per NFPA 13D or 13R 1 to 1-3/4 inches below bottom of beam.	Recessed using Style 20 Escutcheon or non-recessed per NFPA 13D, 13R, or 13	8 (2,4)
14 x 14 (4,3 x 4,3)	16 (60,6)	7.6 (0,52)	16 (60,6)	7.6 (0,52)			
16 x 16 (4,9 x 4,9)	16 (60,6)	7.6 (0,52)	16 (60,6)	7.6 (0,52)			
18 x 18 (5,5 x 5,5)	18 (68,1)	9.6 (0,66)	18 (68,1)	9.6 (0,66)			
20 x 20 (6,1 x 6,1)	20 (75,7)	11.9 (0,82)	20 (75,7)	11.9 (0,82)			

- (a) For coverage area dimensions less than or between those indicated, use the minimum required flow for the next highest coverage area for which hydraulic design criteria are stated.
- (b) Requirement is based on minimum flow in GPM (LPM) from each sprinkler. The associated residual pressures are calculated using the nominal K-factor. Refer to Hydraulic Design under the Design Criteria section.
- (c) For NFPA 13 residential applications, the greater of 0.1 gpm/ft² over the design area or the flow in accordance with the criteria in this table must be used.

TABLE A
WET PIPE SYSTEM
SERIES LFII RESIDENTIAL PENDENT AND RECESSED PENDENT SPRINKLERS (TY3934)
NFPA 13D, 13R, AND 13 HYDRAULIC DESIGN CRITERIA

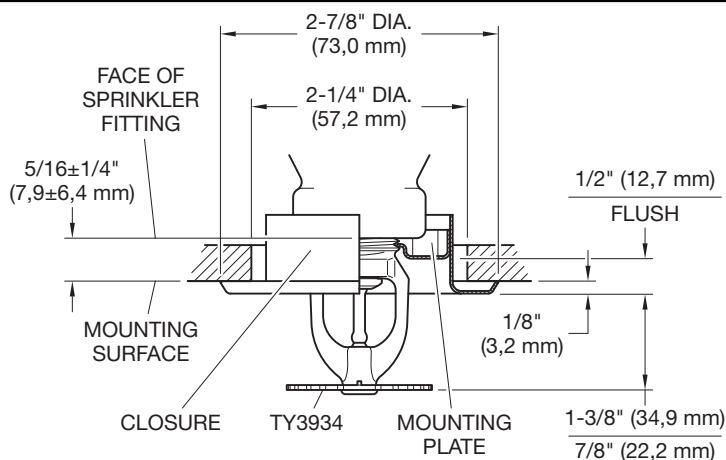

FIGURE 2
STYLE 20 RECESSED ESCUTCHEON FOR USE WITH THE RAPID RESPONSE SERIES LFII RESIDENTIAL PENDENT SPRINKLER (TY3934)

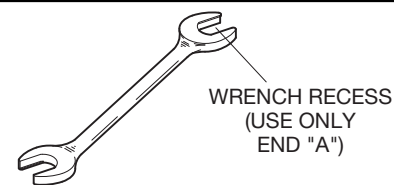

FIGURE 3
W-TYPE 6 SPRINKLER WRENCH

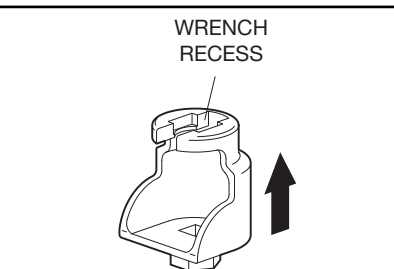

FIGURE 4
W-TYPE 7 RECESSED SPRINKLER WRENCH

Series LFII Residential Recessed Pendant Sprinkler Installation

The Series LFII Residential Recessed Pendant Sprinklers must be installed in accordance with the following instructions.

Step A. Install recessed pendant sprinklers in the pendant position with the deflector parallel to the ceiling.

Step B. After installing the Style 20 Mounting Plate over the sprinkler threads and with pipe thread sealant applied to the pipe threads, hand-tighten the sprinkler into the sprinkler fitting.

Step C. Tighten the sprinkler into the sprinkler fitting using only the W-Type 7 Recessed Sprinkler Wrench (Figure 4). With reference to Figure 1, apply the W-Type 7 Recessed Sprinkler Wrench to the sprinkler wrench flats.

Step D. After the ceiling has been installed or the finish coat has been applied, slide on the Style 20 Closure over the Series LFII Residential Sprinkler and push the Closure over the Mounting Plate until its flange comes in contact with the ceiling.

Care and Maintenance

The TYCO RAPID RESPONSE Series LFII Residential Pendent and Recessed Pendent Sprinklers (TY3934) must be maintained and serviced in accordance with this section.

Before closing a fire protection system main control valve for maintenance work on the fire protection system that it controls, permission to shut down the affected fire protection system must be obtained from the proper authorities and notify all personnel who may be affected by this action.

Absence of the outer piece of an escutcheon, which is used to cover a clearance hole, can delay sprinkler operation in a fire situation.

The owner must assure that the sprinklers are not used for hanging any objects and that the sprinklers are only cleaned by means of gently dusting with a feather duster; otherwise, non-operation in the event of a fire or inadvertent operation may result.

Sprinklers which are found to be leaking or exhibiting visible signs of corrosion must be replaced.

Automatic sprinklers must never be painted, plated, coated, or other-

wise altered after leaving the factory. Modified sprinklers must be replaced. Sprinklers that have been exposed to corrosive products of combustion, but have not operated, should be replaced if they cannot be completely cleaned by wiping the sprinkler with a cloth or by brushing it with a soft bristle brush.

Care must be exercised to avoid damage to the sprinklers - before, during, and after installation. Sprinklers damaged by dropping, striking, wrench twist/slippage, or the like, must be replaced. Also, replace any sprinkler that has a cracked bulb or that has lost liquid from its bulb. (Ref. Installation Section.)

The owner is responsible for the inspection, testing, and maintenance of their fire protection system and devices in compliance with this document, as well as with the applicable standards of the National Fire Protection Association (e.g., NFPA 25), in addition to the standards of any authorities having jurisdiction. Contact the installing contractor or product manufacturer regarding any questions.

Automatic sprinkler systems are recommended to be inspected, tested, and maintained by a qualified Inspection Service in accordance with local requirements and/or national codes.

Limited Warranty

For warranty terms and conditions, visit www.tyco-fire.com.

Ordering Procedure

Contact your local distributor for availability. When placing an order, indicate the full product name and Part Number (P/N).

Sprinkler Assembly

Specify: Series LFII (TY3934), K = 5.8, Residential Pendent Sprinkler, (specify) temperature rating, (specify) finish, P/N (specify):

155°F (68°C)

Natural Brass	51-058-1-155
Pure White (RAL 9010)*	51-058-3-155
Signal White (RAL 9003)	51-058-4-155
Jet Black (RAL 9005)	51-058-5-155
Chrome Plated	51-058-9-155

175°F (79°C)

Natural Brass	51-058-1-175
Pure White (RAL 9010)*	51-058-3-175
Signal White (RAL 9003)	51-058-4-175
Jet Black (RAL 9005)	51-058-5-175
Chrome Plated	51-058-9-175

*Eastern Hemisphere sales only

Recessed Escutcheon

Specify: Style 20 Recessed Escutcheon with (specify*) finish, P/N (specify*)

*Refer to Technical Data Sheet TFP770

Sprinkler Wrench

Specify: W-Type 6 Sprinkler Wrench, P/N 56-000-6-387

Specify: W-Type 7 Sprinkler Wrench, P/N 56-850-4-001