

DV-5 Red-E Cabinet Integrated Preaction Fire Protection Package

General Description

The TYCO DV-5 Red-E Cabinet is a pre-assembled fire protection valve package enclosed within a free-standing cabinet designed to occupy minimal floor space and to provide an aesthetically pleasing enclosure for a fire protection valve riser. The entire package is pre-wired and the water inlet and outlets to the valve riser are grooved to provide minimal installation time. The valve package includes the system (manual) shut-off control valve, automatic water control valve, and water-flow/supervisory switches. A built-in air compressor with associated controls provides an automatic air supply for use as either supervision or automatic water control valve actuation.

Integral to the DV-5 Red-E Cabinet is a control panel and back-up batteries for providing electrical alarm, supervisory, and trouble functions. All switches within the cabinet are pre-wired to the control panel, making the electrical connections for power, detection circuits, and alarms the only remaining connections to complete the system.

In addition to the control panel being integral to the DV-5 Red-E Cabinet, windows have been provided in the door for viewing the releasing panel functions and essential system pressure gauges. A lock for the control panel access door is standard, and a lock for the cabinet door is optional.

Features and benefits are as follows:

- aesthetically pleasing appearance
- professionally assembled
- internally wired
- custom manufactured
- all gauges and panel display are externally visible
- removable side panels for ease of maintenance
- furniture grade rollers (4) are standard at bottom of cabinet

The DV-5 Red-E Cabinet has been designed to readily incorporate 1-1/2 through 8 inch (DN40 thru DN200) valve risers for the following types of preaction systems:

- Single Interlock Preaction Systems
- Electric Actuation
- Dry Pilot Actuation
- Wet Pilot Actuation Double Interlock Preaction System
- Electric/Electric Actuation
- Electric/Pneumatic Actuation

NOTICE

The DV-5 Red-E Cabinets described herein must be installed and maintained in compliance with this document and with the applicable standards of the National Fire Protection Association (NFPA), in addition to the standards of any authorities having jurisdiction. Failure to do so may impair the performance of these devices.

The owner is responsible for maintaining their fire protection system and devices in proper operating condition. Contact the installing contractor or product manufacturer with any questions.

Technical Data

Approvals

The 1-1/2 thru 8 inch (DN40 thru DN200) DV-5 Red-E Cabinets are UL Listed and C-UL Listed with the following system types:

- Single Interlock Preaction with Electric Actuation
- Single Interlock Preaction with Dry Pilot Actuation
- Single Interlock Preaction with Wet Pilot Actuation
- Double Interlock Preaction with Electric/Electric Actuation
- Double Interlock Preaction with Electric/Pneumatic Actuation

The 1-1/2 thru 8 inch (DN40 thru DN200) DV-5 Red-E Cabinets are FM Approved with the following system types:



- Single Interlock Preaction with Electric Actuation
- Double Interlock Preaction with Electric/Electric Actuation
- Double Interlock Preaction with Electric/Pneumatic Actuation

System Types

The Technical Data Sheets referenced in Table B provide complete details for each system type arrangement.

Working Pressure Range

20 to 250 psi (1,4 to 17,2 bar)

Construction

The Red-E Cabinet is constructed of 14 gauge steel and is free standing. The standard paint finish is bright red. The front door of the enclosure is fully hinged (and removable) and opens nearly to the cabinet floor level allowing easy access to the couplings when connecting the water supply and drain. The cabinet roof is a removable panel that allows access to the Compressor. Pre-drilled holes in the cabinet floor provide an anchor point for the cabinet to be secured to the floor when required. All four sides of the cabinet can be removed for ease of maintenance, and furniture grade rollers at the bottom of the cabinet are standard. Internal controls that provide functions to reset a system after operation (e.g., alarm test valve, main drain valve, etc.) are individually tagged for easy identification. All prefabricated piping is Schedule 40 steel.

DIM	Description	Nominal Riser Size Nominal Dimension in Inches and (millimeters) ¹					
		1-1/2 (DN40)	2 (DN50)	3 (DN80)	4 (DN100)	6 (DN150)	8 (DN200)
A	System Discharge	1-1/2 (DN40)	2 (DN50)	3 (DN80)	4 (DN100)	6 (DN150)	8 (DN200)
B	Supply Header	3 (DN80)			6 (DN150)		8 (DN200)
C	Drain Header	2 (DN50)					
D	Header Left	12-1/4 (311)			16-1/2 (420)		17-3/4 (451)
E	Header Right	12-1/4 (311)			13 (330)		14-1/4 (362)
F	Riser Height	66 (1676)	66 (1676)	66 (1676)	74 (1880)	74 (1880)	78-3/4 (2000)
G	Connection Offset	9-1/4 (235)					
H	Connection Offset	10-1/8 (257)			14-1/8 (359)		15-1/8 (385)
J	Connection Offset	4-1/8 (105)			8-1/8 (206)		9-1/8 (232)
K	Connection Offset	6 (152)					
L	Connection Offset	5-1/8 (130)			5-1/8 (130)		
M	Connection Offset	14-1/4 (362)			16 (406)		15-1/2 (394)
N	Cabinet Height	70-9/16 (1792)			78-1/2 (1994)		82-5/8 (2099)
P	Cabinet Width	28-1/2 (725)			36 (915)		36 (914)
R	Cabinet Depth	20-1/2 (520)			28-3/16 (716)		32-3/16 (818)

1. All pipe connections are grooved
2. Supply and drain header connections made internal to cabinet

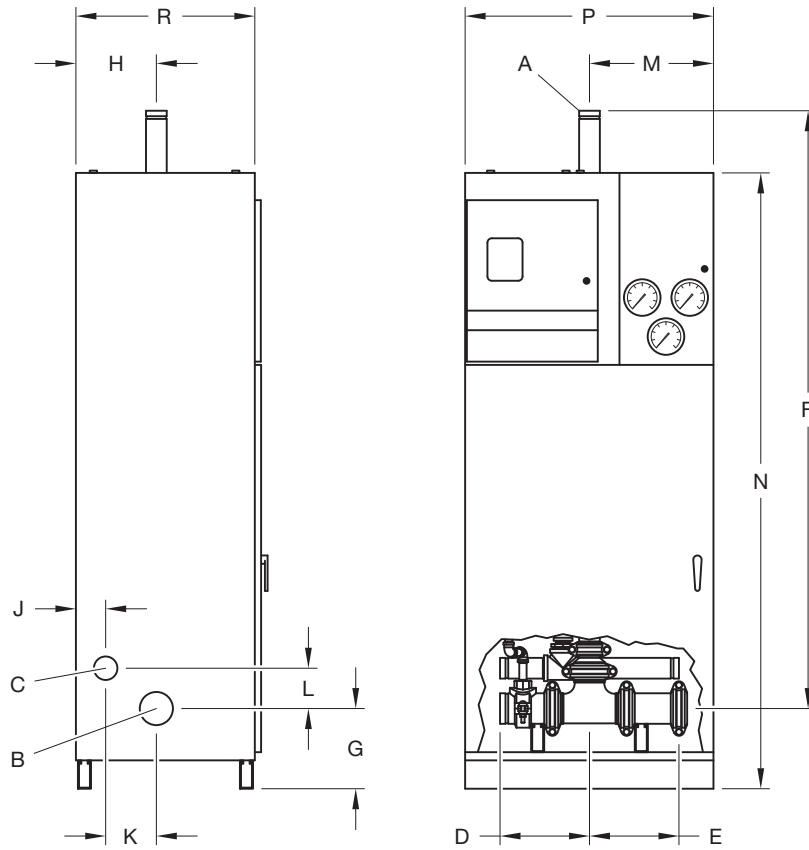
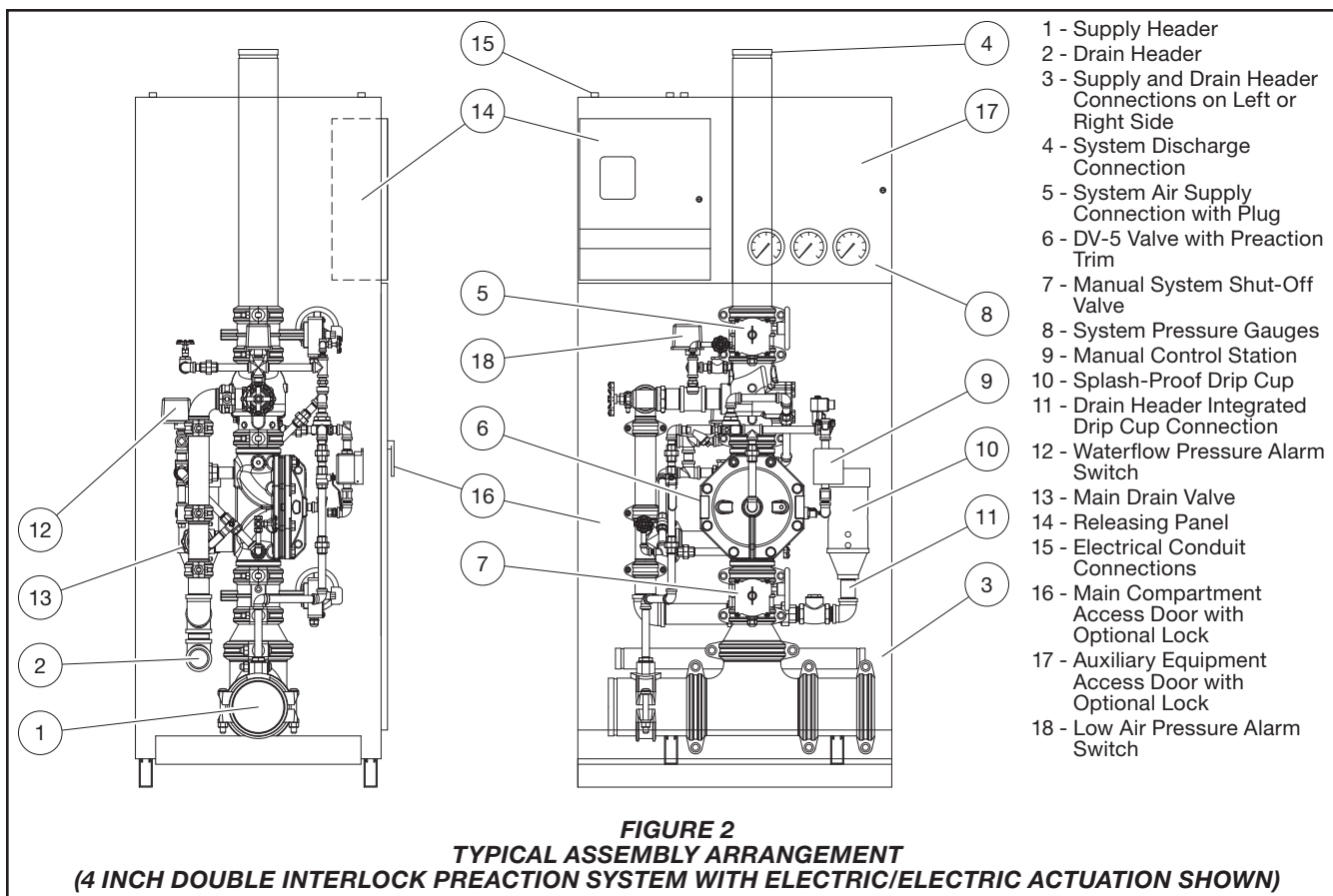

FIGURE 1
INSTALLATION DIMENSIONS AND REFERENCE POINTS



A Splash-Proof Drain Cup is provided with a Splash Cover that ensures water does not splash into the cabinet during flow testing. The discharging water can be observed through the clear portion of the cover. It is designed with a fail-safe feature allowing water to overflow in the event the drain is blocked.

The Hard Piped Funnel Drain is connected through a Swing Check Valve to the Main Drain Header, eliminating the need to run a separate drain line from the funnel. The cabinet floor is provided with a drain opening to allow water to drain out. A plug is also provided to prevent water from draining from the cabinet if necessary.

The Air Supply connection for cabinets without compressors (using AMD-1) are terminated at a common height across all model sizes allowing the connection of groups of cabinets easier. This allows a single tank mounted compressor sized to meet the requirements of the largest system in the group to supply all the cabinets in the group, or alternatively, connect to the factory air supply. The air supply line contains a tee and plug which is used to connect a hydraulic test pump that pressurizes the sprinkler system above the check valve for hydraulic testing of the system in accordance with NFPA 13.

Table A provides list of riser components and a cross reference to individual Technical Data Sheets, as well as individual component laboratory approval information.

Figure 1 provides dimensional information for Red-E Cabinets, and Figure 2 illustrates the typical assembly arrangement.

Design Considerations

The automatic sprinklers and/or nozzles, fire detection devices, manual pull stations, and signaling devices that are to be utilized with the Red-E Cabinet must be UL Listed, ULC Listed, C-UL Listed, or FM Approved, as applicable. With reference to Figure 3, the system designer must consider and make preparations for use of a Red-E Cabinet as follows:

- adequate floor space to facilitate opening of the cabinet door
- minimum ambient temperature of 40°F (4°C)
- installation of a suitably sized water supply to the water supply header (Port B, Figure 1)

- installation of system piping (Port A, Figure 1) including automatic sprinklers and/or nozzles from the Red-E cabinet outlet
- installation of drains from main drain header (Port C, Figure 1)
- installation of the detection system components and alarms
- determination of air compressor size for double interlock preaction systems as a function of system type and volume (Table C)
- power supply to Red-E Cabinet
- separate power supply to the air compressor

Installation

The TYCO Red-E Cabinet is to be installed following the directions given in the "Red-E Cabinet Installer's Manual" provided with the Red-E Cabinet. Instructions pertain to the following items:

- placing the cabinet
- connecting the system piping
- electrical connections
- system start-up

Description	Model	TDS	UL	C-UL/ULC	FM Global	CSA
System Shut-off Valve, 1-1/2" (DN40)	Lansdale Powerball 51024A		X ⁵	X ⁵	X ⁵	
System Shut-off Valve, 2"-8" (DN50-DN200)	BFV-300	TFP1511	X	X	X	
Automatic Water Control Valve	DV-5	TFP1305	X	X	X	
Actuation Trim						
Single Interlock (Electric)		TFP1420	X	X	X	
Single Interlock (Dry Pilot)		TFP1415	X	X	X	
Single Interlock (Wet Pilot)		TFP1410	X	X	X	
Double Interlock (Electric/Electric)		TFP1465	X	X	X	
Double Interlock (Electric/Pneumatic)		TFP1460	X	X	X	
Pressure Alarm Switch	PS10-2A		X ⁶	X ⁶	X ⁶	
Pressure Alarm Switch	PS40-2A		X ⁶	X ⁶	X ⁶	
Control Panel ¹	PFC-4410RC		X ⁶	X ⁶	X ⁶	
Automatic Supervisory Air Supply ²	G16AC812	TFP1620	X ⁷			X ⁷
Air Maintenance Device ³ , Regulator Type	AMD-1	TFP1221	X	X	X	
Air Maintenance Device ⁴ , Switch Type	AMD-2	TFP1231	X	X	X	
Nitrogen Maintenance Device ⁴	AMD-3	TFP1241	X	X	X	

Notes:

1. The Model PFC-4410RC is standard. The Red-E Cabinet may be ordered without an integral control panel.
2. The Model G16AC812 is utilized to maintain supervisory air pressure in all sizes of Single Interlock Preaction Systems with either Electric Actuation or Wet Pilot Actuation.
3. The Model AMD-1 Air Maintenance Device, in addition to an Auxiliary Air Tank, is utilized as standard equipment in Single Interlock Preaction Systems with Dry Pilot Actuation, as well as Double Interlock Preaction Systems with Electric/Electric Actuation. In the case of Single Interlock Preaction Systems with Dry Pilot Actuation, two AMD-1's are utilized to accomplish the two different pressure settings that are necessary for the system piping and the dry pilot line. In the case of Double Interlock Preaction Systems with Electric/Electric Actuation, one AMD-1 is utilized to maintain the system pressure.
4. The Model AMD-2 Air Maintenance Device and Model AMD-3 Nitrogen Maintenance Device, as well as the Model AMD-1 Air Maintenance Device, are offered as options when the Red-E Cabinet is ordered without a built-in (i.e., air compressor) automatic air supply.
5. Approvals under the name of the valve company.
6. Approvals under the name of Potter Electric Signal Company.
7. Approvals for the Compressor and Motor are under the name of General Air Company, and the approvals for the Pressure Operated Switch are under the name of Hubble or Condor.

TDS – Technical Data Sheet

TABLE A
PRINCIPAL COMPONENTS
TECHNICAL DATA SHEETS AND LABORATORY APPROVALS

System Type	Refer to the Following Technical Data Sheets for Complete Operation Details
Single Interlock, Electric Actuation	TFP1420
Single Interlock, Dry Pilot Actuation	TFP1415
Single Interlock, Wet Pilot Actuation	TFP1410
Double Interlock, Electric/Pneumatic Actuation	TFP1460
Double Interlock, Electric/Electric Actuation	TFP1465

TABLE B
SYSTEM TYPES AND OPERATION

Care and Maintenance

The TYCO DV-5 Red E-Cabinet must be maintained and serviced in accordance with this section.

Before closing a fire protection system main control valve for maintenance work on the fire protection system that it controls, permission to shut down the affected fire protection systems must first be obtained from the proper authorities. All personnel who may be affected by this decision must be notified.

Inspection, testing, and maintenance must be performed in accordance with the requirements of the NFPA, and any impairment must be immediately corrected.

The TYCO Red-E Cabinet does not require any regularly scheduled inspection or maintenance. The riser components enclosed within the Red-E Cabinet, however, must be maintained in accordance with their applicable Technical Data Sheet (Table A). In addition, the Control Panel and Automatic Air Supply components must be maintained in accordance with their applicable instructions provided with the Red-E Cabinet.

The owner is responsible for the inspection, testing, and maintenance of their fire protection system and devices in compliance with this document, as well as with the applicable standards of any authorities having jurisdiction. Contact the installing contractor or product manufacturer with any questions.

Automatic sprinkler systems are recommended to be inspected, tested, and maintained by a qualified Inspection Service in accordance with local requirements and/or national codes.

Red-E Cabinet Technical Support

Technical support for the Red-E Cabinet is available by calling 888-572-4638 during regular business hours of 8:30-12:00 and 1:00-5:00 Eastern Time Monday through Friday.

Contact Red-E Cabinet Technical Support for special request cabinet configuration or electrical connection/control panel programming inquiries.

An answering service will take messages outside of the regular business hours.

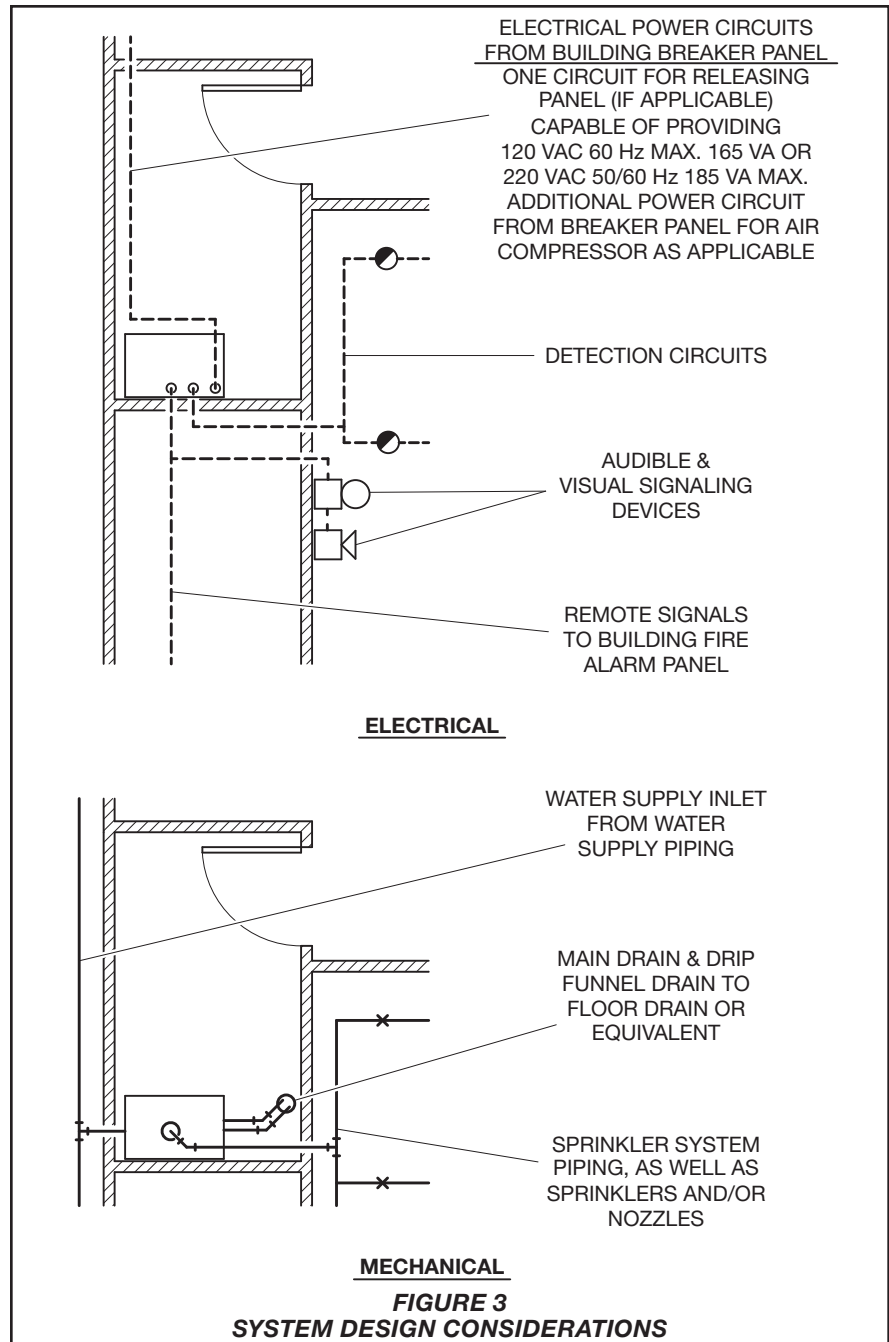

Model Number	Horsepower	Voltage ¹	Electric/Electric Actuation	Electric/Pneumatic Actuation
			System Volume, Gallons (L) 20 psi in 30 min.	System Volume, Gallons (L) 40 psi in 30 min.
OL12516AC	1/6	115, 60 Hz	290 (1095)	125 (473)
OL25033AC	1/3	115, 60 Hz	475 (1795)	250 (945)
OL36550AC	1/2	115/230, 60 Hz	780 (2950)	365 (1380)
OL43075AC ²	3/4	115/230, 60 Hz	930 (3520)	430 (1625)
OL615100AC ²	1	115/230, 60 Hz	1430 (5410)	615 (2325)
OL915100AC ²	1-1/2	115/230, 60 Hz	2320 (8780)	915 (3460)
OL1225200AC ²	2	230, 60 Hz	3040 (11500)	1225 (4635)

Notes:
1. Unless otherwise specified, 115 VAC, 60 Hz is provided
2. 4, 6, and 8 Inch (DN100, 150, and 200) cabinets only

TABLE C
AIR COMPRESSOR SELECTION FOR DOUBLE INTERLOCK PREACTION SYSTEM ARRANGEMENTS
BASED ON SYSTEM TYPE AND SYSTEM VOLUME

P/N 52 – 9XX – X – XXX

Size Inch	Actuation Device	Air Maintenance Device ¹	Trim Type ²	Control Panel	Compressor ¹
1	4 S/I Wet	0 None	1 Galvanized	0 None	0 None
2	5 S/I Dry	1 AMD-1		A Included	1 1/6 hp 125 Gal
3	6 S/I Electric	2 AMD-2			2 1/3 hp 250 Gal
4	7 D/I Electric/ Pneumatic	3 AMD-3			3 1/2 hp 365 Gal
6	8 D/I Electric/ Electric				4 3/4 hp 430 Gal
8					5 1 hp 615 Gal
					6 1-1/2 hp 915 Gal
					7 2 hp Gal*
					8 S/I Compressor

1. Air Maintenance Device is not required (select "0" - None) when a Compressor (1-8) is selected.
2. Black and brass trim types are available only on request. Contact Red-E Cabinet Technical Support for information.

* Requires 230V/60Hz

TABLE D
DV-5 RED-E CABINET
PART NUMBER SELECTION

Limited Warranty

For warranty terms and conditions, visit www.tyco-fire.com.

Ordering Procedure

The Part Numbers (P/Ns) in this section are provided for standard cabinets with integral control panel, built-in automatic air supply (i.e., air compressor and controls), and galvanized pipe (except supply header which is black), nipples, and fittings.

DV-5 Red-E Cabinet with Single Interlock Preaction System

Specify: (size) Inch DV-5 Red-E Cabinet with (specify actuation) Single Interlock Preaction System Riser for installation in (USA or Canada), P/N (specify per Table D)

NOTICE

Electric Actuation and Wet Pilot Actuation are provided standard with the Model G16AC812 Automatic Air Supply utilizing a 1/6 HP motor. Dry Pilot Actuation is provided standard with an OL12516AC (1/6 HP) Air Compressor and Auxiliary Air Tank complete with Model AMD-1 Air Maintenance Devices.

DV-5 Red-E Cabinet with Double Interlock Preaction System and Electric/Electric Actuation

Specify: (size) Inch DV-5 Red-E Cabinet with Electric/Electric-Actuated Double Interlock Preaction System Riser with (specify model from Table C) Air Compressor for installation in (USA or Canada), P/N (specify per Table D)

DV-5 Red-E Cabinet with Double Interlock Preaction System and Electric/Pneumatic Actuation

Specify: (size) Inch DV-5 Red-E Cabinet with Electric/Pneumatic-Actuated Double Interlock Preaction System Riser with (specify model from Table C) Air Compressor for installation in (USA or Canada), P/N (specify per Table D)

Special Orders

The DV-5 Red-E Cabinet can be provided as follows as part of a special request cabinet configuration:

- without the control panel
- without built-in automatic air supply (i.e., air compressor and controls)
- with an optional air/nitrogen maintenance device when ordered without built-in automatic air supply
- with trim black pipe, nipples, and fittings, as may be desired for AFFF systems
- with special size air compressors for single interlock systems
- with 50 Hz air compressors

Options

- with sight flow gage (provides a visual indication of flow through the main drain)
- with extra capacity batteries (12V up to 18Ah) for longer battery time and/or systems with heavy power requirements (e.g., numerous audible signaling devices)
- with Class "A" initiating appliance circuits (this option permits the connection of Class "A" style wiring to the initiating zones)
- with Class "A" indicating appliance circuits (this option permits the connection of Class "A" style wiring to the indicating zones)
- with auxiliary relay modules to provide extra-dry contacts when required; up to an 8 ARM-44 module per cabinet can be added
- with RA-4410 RC Remote Annunciator

Contact Red-E Cabinet Technical Support for information about special request cabinet configurations.

