

tyco Fire Suppression & Building Products

Technical Services: Tel: (800) 381-9312 / Fax: (800) 791-5500

Model DV-5 Deluge Valve, Aluminum Bronze, 2 thru 8 Inch (DN50 thru DN200), 250 psi (17,2 bar) Vertical or Horizontal Installation

General Description

The Tyco® Aluminum Bronze Model DV-5 Deluge Valves are available to provide an alternative materials of construction to that of the standard nylon coated ductile iron Model DV-5 deluge Valve described in Technical Data Sheet TFP1305, TFP1335, and TFP1338. The 2 thru 8 inch (DN50 thru DN200), Aluminum Bronze Model DV-5 Deluge Valves are diaphragm type valves designed for vertical or horizontal installation and for fire protection system service. They are used as "automatic water control valves" in deluge fire protection systems. The alternate materials of construction are offered for use in corrosive environments where the standard nylon coated ductile iron would not be suitable, i.e. situations where the system is continuously charged with sea water.

The diaphragm style design of the DV-5 Valve allows external resetting — providing for easy resetting of a deluge system without having to open a valve handhole cover to manually reposition a clapper and/or latch mechanism. Simply re-pressurizing the diaphragm chamber resets the valve.

NOTICE

The Model DV-5 Deluge Valves described herein must be installed and maintained in compliance with this document and with the applicable standards of the National Fire Protection Association, in addition to the standards of any other authorities having jurisdiction. Failure to do so may impair the performance of these devices.

The owner is responsible for maintaining their fire protection system and de-



End Connections Available and Weights

End Connection		Nominal Valve Size				
Inlet	Outlet	2 Inch (DN50)	3 Inch (DN80)	4 Inch (DN100)	6 Inch (DN150)	8 Inch (DN200)
Flange	Flange	21 lbs. (9,5 Kg)	43 lbs. (19,5 Kg)	90 lbs. (40,8 Kg)	126 lbs. (57,2 Kg)	215 (97,5 Kg)

vices in proper operating condition. The installing contractor or manufacturer should be contacted with any questions.

VALVE PARTS		
NO.	DESCRIPTION	QTY.
1	Valve Body	1
2	Diaphragm	1
3	Handhole Cover	1
4	Flat Washer, 2 & 3 Inch Valves, M16	4
	4 & 6 Inch Valves, M16	8
	8 Inch Valves, M20	8
5	Hex Bolt, 2 & 3 Inch Valves, M16 x 50	4
	4 Inch Valve, M16 x 50	6
	6 Inch Valve, M16 x 55	6
	8 Inch Valve, M20 x 70	6
6	Hex Nut, 4 & 6 Inch Valves, M16	2
	8 Inch Valves, M20	2

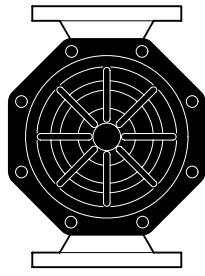

Diaphragm
Tab Oriented
Perpendicular
To Valve Body

Studs,
See Note

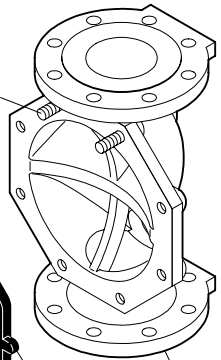

Diaphragm
Orientation
Tab

NOTE:

4, 6, & 8 Inch Valve Bodies are equipped with studs as shown, allowing Diaphragm and Handhole Cover to be "hung" in place to ease assembly. Bodies of 2 and 3 Inch Valves are not equipped with studs.

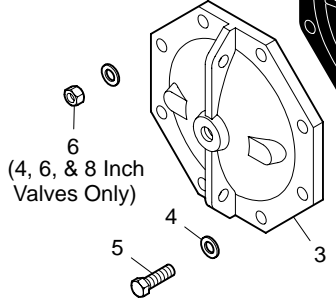

6
(4, 6, & 8 Inch
Valves Only)

FIGURE 1
2 thru 8 INCH (DN50 thru DN200) ALUMINUM BRONZE MODEL DV-5 DELUGE VALVE
— ASSEMBLY —

Port Description	Port	Port Sizes in NPT per ANSI B1.20.1 *				
		2 Inch (DN50)	3 Inch (DN80)	4 Inch (DN100)	6 Inch (DN150)	8 Inch (DN200)
Diaphragm Chamber Supply	P1	1/2"	1/2"	1/2"	1/2"	1/2"
Water Supply Pressure & Alarm Test	P2	1/2"	1/2"	1/2"	1/2"	1/2"
Alarm Actuation & System Drain	P3	3/4"	3/4"	1"	1"	1"
Main Drain	P4	3/4"	1-1/4"	2"	2"	2"
Diaphragm Chamber Supply Automatic Shut-Off Valve Actuation	P5	1/2"	1/2"	1/2"	1/2"	1/2"

* Valves are available with ports threaded per ISO 7/1.

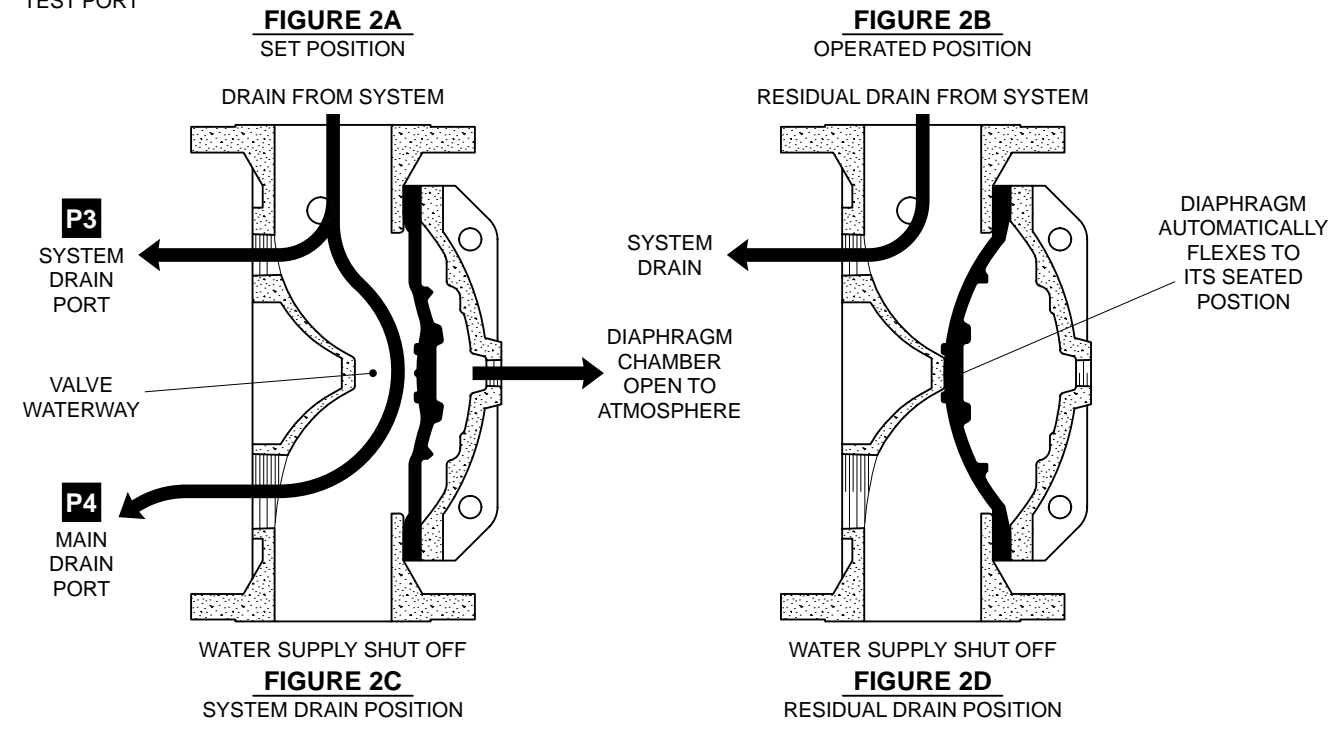
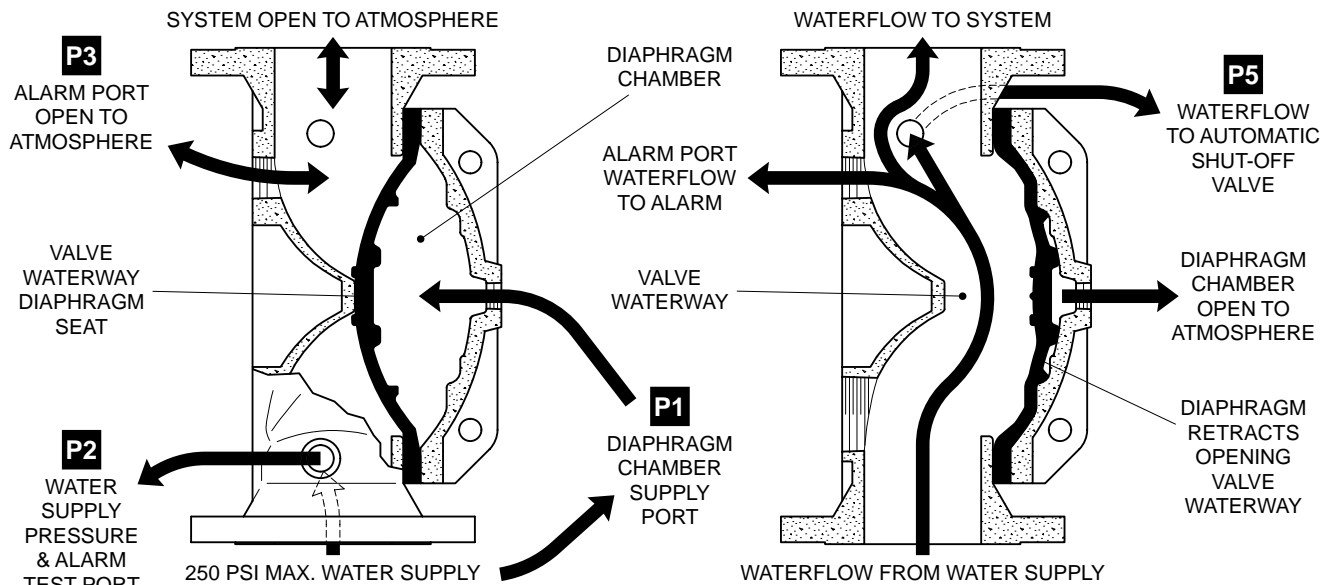
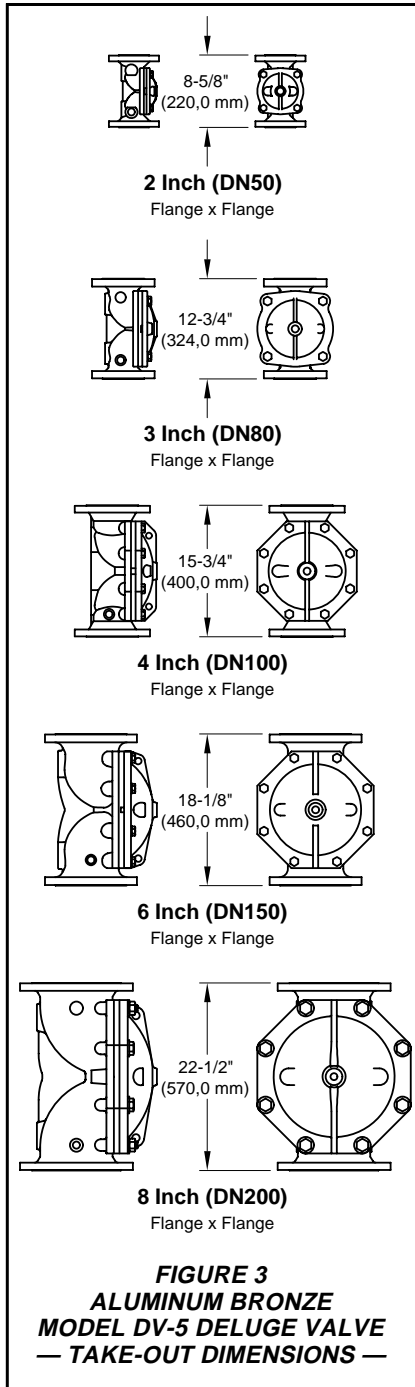

FIGURE 2
2 thru 8 INCH (DN50 thru DN200) ALUMINUM BRONZE MODEL DV-5 DELUGE VALVE
— SET AND OPEN POSITIONS —



Technical Data

Approvals:

The Aluminum Bronze Model DV-5 Deluge Valves are FM Approved, when trimmed per the following Technical Data Sheets:

- Deluge Systems:
TFP1310 - Wet Pilot Actuation
TFP1315 - Dry Pilot Actuation
TFP1320 - Electric Actuation
- Single Interlock Preaction Systems:
TFP1420 - Electric Actuation
- Double Interlock Preaction Systems:
TFP1460 - Electric/Pneumatic
TFP1465 - Electric/Electric
- European Conformity
TFP1335

The aluminum bronze, Model DV-5 Deluge Valves are VdS Approved, when trimmed per Technical Data Sheet TFP1338.

Deluge Valve:

Components for the 2 thru 8 inch (DN50 thru DN200), Model DV-5 Deluge Valves are shown in Figure 1. The DV-5 Valves are for vertical or horizontal installations, and they are rated for use at a maximum service pressure of 250 psi (17,2 bar).

The Aluminum Bronze Model DV-5 Deluge Valve is provided with custom manufactured flange connections (thickness, outside diameter, bolt circle, bolt holes, raised or flush faced) in accordance with most recognized flange specifications. For example:

- ANSI B16.5 (Class 150)
- ANSI B16.42 (Class 150)
- ISO 7005-2 (PN10)
- ISO 7005-2 (PN16)
- JIS B2210 (10K)
- AS2129 (Table E)

The take-out dimensions are shown in Figure 3.

Threaded port connections of the Aluminum Bronze DV-5 Deluge Valves are available NPT threaded or threaded per ISO 7/1.

Patents:

U.S.A. : 6,095,484

Materials Of Construction

NOTICE

The materials of construction for the Aluminum Bronze Model DV-5 Deluge Valve provide corrosion resistance and are intended to extend the life of the DV-5 Valve when exposed to internal and external corrosive conditions. Although the materials of construction for the Aluminum Bronze Model DV-5 Deluge Valve are intended to resist corrosion, it is recommended that the end user or other technical expert familiar with conditions at the proposed installation be consulted with respect to the suitability of this coating for a given corrosive condition.

Body. Aluminum Bronze AB2 per BS1400 (UNS C63000).

Handhole Cover. Aluminum Bronze AB2 per BS1400 (UNS C63000).

Diaphragm. Ethylene propylene diene M-class rubber (EPDM)

Diaphragm Cover Fasteners. Type 316 stainless steel, unless otherwise specified at time of order.

Operating Principles

The Tyco® Aluminum Bronze Model DV-5 Deluge Valve is a diaphragm style valve that depends upon water pressure in the Diaphragm Chamber (Ref. Figure 2A) to hold the Diaphragm closed against the water supply pressure. When the DV-5 Valve is set for service, the Diaphragm Chamber is pressurized through the trim connections from the inlet side of the system's main control valve. Opening an actuation device, releases water from the Diaphragm Chamber faster than it can be replenished through an 1/8 inch (3,2 mm) restriction provided in the diaphragm chamber supply connection. This results in a rapid pressure drop in the Diaphragm Chamber and the force differential applied through the Diaphragm to hold the Diaphragm in the set position is reduced below the valve trip point. The water supply pressure then forces the Diaphragm open permitting water to flow into the system piping.

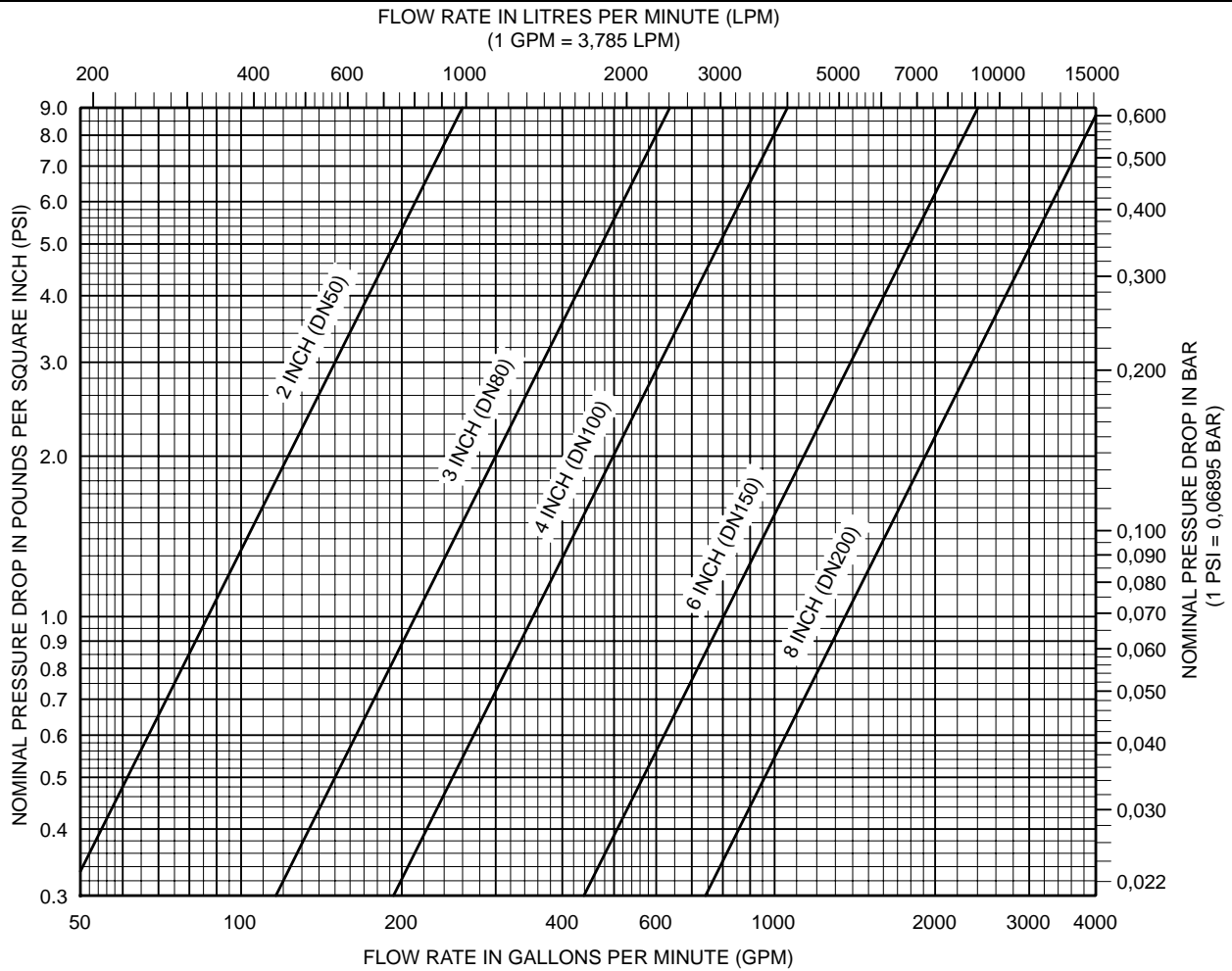

The approximate friction loss, based on the Hazen and Williams formula and expressed in equivalent length of pipe with C=120, is as follows:

- 16 feet of 2 inch Sch. 40 pipe for the 2 inch DV-5 Valve calculated on a typical flow rate of 175 GPM.
- 20 feet of 3 inch Sch. 40 pipe for the 3 inch DV-5 Valve calculated on a typical flow rate of 350 GPM.
- 29 feet of 4 inch Sch. 40 pipe for the 4 inch DV-5 Valve calculated on a typical flow rate of 600 GPM.
- 46 feet of 6 inch Sch. 40 pipe for the 6 inch DV-5 Valve calculated on a typical flow rate of 1500 GPM.
- 72 feet of 8 inch Sch. 30 pipe for the 6 inch DV-5 Valve calculated on a typical flow rate of 2500 GPM.

GRAPH A
2 thru 8 INCH (DN50 thru DN200) ALUMINUM BRONZE MODEL DV-5 DELUGE VALVE
— NOMINAL PRESSURE LOSS VERSUS FLOW —

Installation

NOTICE

Proper operation of the Model DV-5 Deluge Valves depends upon their trim being installed properly for a given application. Failure to install the appropriate trim may prevent the DV-5 Valve from functioning properly, as well as void listings, approvals, and the manufacturer's warranties.

The DV-5 Valve must be installed in a readily visible and accessible location.

The DV-5 Valve, associated trim, and wet pilot lines must be maintained at a minimum temperature of 40°F/4°C.

Heat tracing of the DV-5 Valve or its associated trim is not permitted. Heat tracing can result in the formation of hardened mineral deposits that are capable of preventing proper operation.

Care and Maintenance

The following procedures and inspections must be performed as indicated, in addition to any specific requirements of the NFPA,

The owner is responsible for the inspection, testing, and maintenance of their fire protection system and devices in compliance with this document, as well as with the applicable standards of the National Fire Protection Association (e.g., NFPA 25), in addition to the standards of any authority having jurisdiction. The installing contractor or product manufacturer should be contacted relative to any questions. Any impairment must be immediately corrected.

Automatic sprinkler systems are recommended to be inspected, tested, and maintained by a qualified Inspection Service in accordance with local requirements and/or national codes.

NOTICE

When the system is using a water supply that attacks aluminum bronze, internal and external inspection of the DV-5 Valve and Trim is essential. Parts showing any signs of corrosion must be replaced to ensure the integrity of the system.

Before closing a fire protection system main control valve for maintenance work on the fire protection system that

it controls, permission to shut down the affected fire protection systems must first be obtained from the proper authorities and all personnel who may be affected by this action must be notified.

Internal Valve Inspection

Once every five years assuming a non-corrosive water supply, during the annual operational test procedure (NFPA 25) and prior to the DV-5 Valve being reset, the interior of the DV-5 Valve must be cleaned and inspected for wear and damage. Damaged or worn parts must be replaced. (Replacement of the Diaphragm every ten years is recommended.)

When reinstalling the Diaphragm Cover, the Diaphragm Cover Fasteners **must be uniformly and securely tightened using a cross-draw sequence**. After tightening, double-check to make certain that all of the Diaphragm Cover Fasteners are securely tightened.

NOTICE

If the water supply contains chemicals which tend to attack an EPDM rubber, or the five year inspection indicates a build-up of debris within the valve that could affect its proper operation, the frequency of the internal valve inspection procedure must be appropriately increased.

If the system has a water supply that attacks aluminum bronze, the frequency of the internal valve inspection procedure must be appropriately increased. (An annual internal valve inspection for a system having a sea water or brackish water supply is recommended.)

With reference to Figure 1, make certain that the Diaphragm is correctly oriented; otherwise, the DV-5 cannot be properly set.

Under-tightening the Diaphragm Cover Bolts can result in leakage past the valve seat.

Limited Warranty

Products manufactured by Tyco Fire Suppression & Building Products (TFSBP) are warranted solely to the original Buyer for ten (10) years against defects in material and workmanship when paid for and properly installed and maintained under normal use and service. This warranty will expire ten (10) years from date of shipment by TFSBP. No warranty is given for products or components manufactured by companies not affiliated by ownership with TFSBP or for products and components which have been subject to misuse, improper installation, corrosion, or which have not been installed, maintained, modified or repaired in accordance with applicable Standards of the National Fire Protection Association, and/or the standards of any other Authorities Having Jurisdiction. Materials found by TFSBP to be defective shall be either repaired or replaced, at TFSBP's sole option. TFSBP neither assumes, nor authorizes any person to assume for it, any other obligation in connection with the sale of products or parts of products. TFSBP shall not be responsible for sprinkler system design errors or inaccurate or incomplete information supplied by Buyer or Buyer's representatives.

In no event shall TFSBP be liable, in contract, tort, strict liability or under any other legal theory, for incidental, indirect, special or consequential damages, including but not limited to labor charges, regardless of whether TFSBP was informed about the possibility of such damages, and in no event shall TFSBP's liability exceed an amount equal to the sales price.

The foregoing warranty is made in lieu of any and all other warranties, express or implied, including warranties of merchantability and fitness for a particular purpose.

This limited warranty sets forth the exclusive remedy for claims based on failure of or defect in products, materials or components, whether the claim is made in contract, tort, strict liability or any other legal theory.

This warranty will apply to the full extent permitted by law. The invalidity, in whole or part, of any portion of this warranty will not affect the remainder.

Ordering Procedure

Aluminum Bronze

Model DV-5 Deluge Valve:

Specify: (specify size) Aluminum Bronze Model DV-5 Deluge Valve with flange connections per (specify flange specification) and with (specify NPT or ISO) threaded ports, P/N (specify).

Note: *The Aluminum Bronze Model DV-5 Deluge Valve is provided with custom manufactured flange connections (thickness, outside diameter, bolt circle, bolt holes, raised or flush faced) in accordance with most recognized flange specifications. For example:*

- ANSI B16.5 (Class 150)
- ANSI B16.42 (Class 150)
- ISO 7005-2 (PN10)
- ISO 7005-2 (PN16)
- JIS B2210 (10K)
- AS2129 (Table E)

For flange specifications other than those noted, please request verification of manufacturability when ordering.

Replacement Valve Parts:

Specify: (description) for use with (specify) size Aluminum Bronze Model DV-5 Deluge Valve.

